

---

# LH 150 Port Litronic

---

## LIEBHERR

Material handling machine

### Generation

6

### Operating weight

130,000 – 220,000 kg\*

### System performance

614 kW

### Engine

400 kW / 543 HP

Stage V

Stage IIIA (compliant)

Tier 4 Final

Electric

\* Without attachment

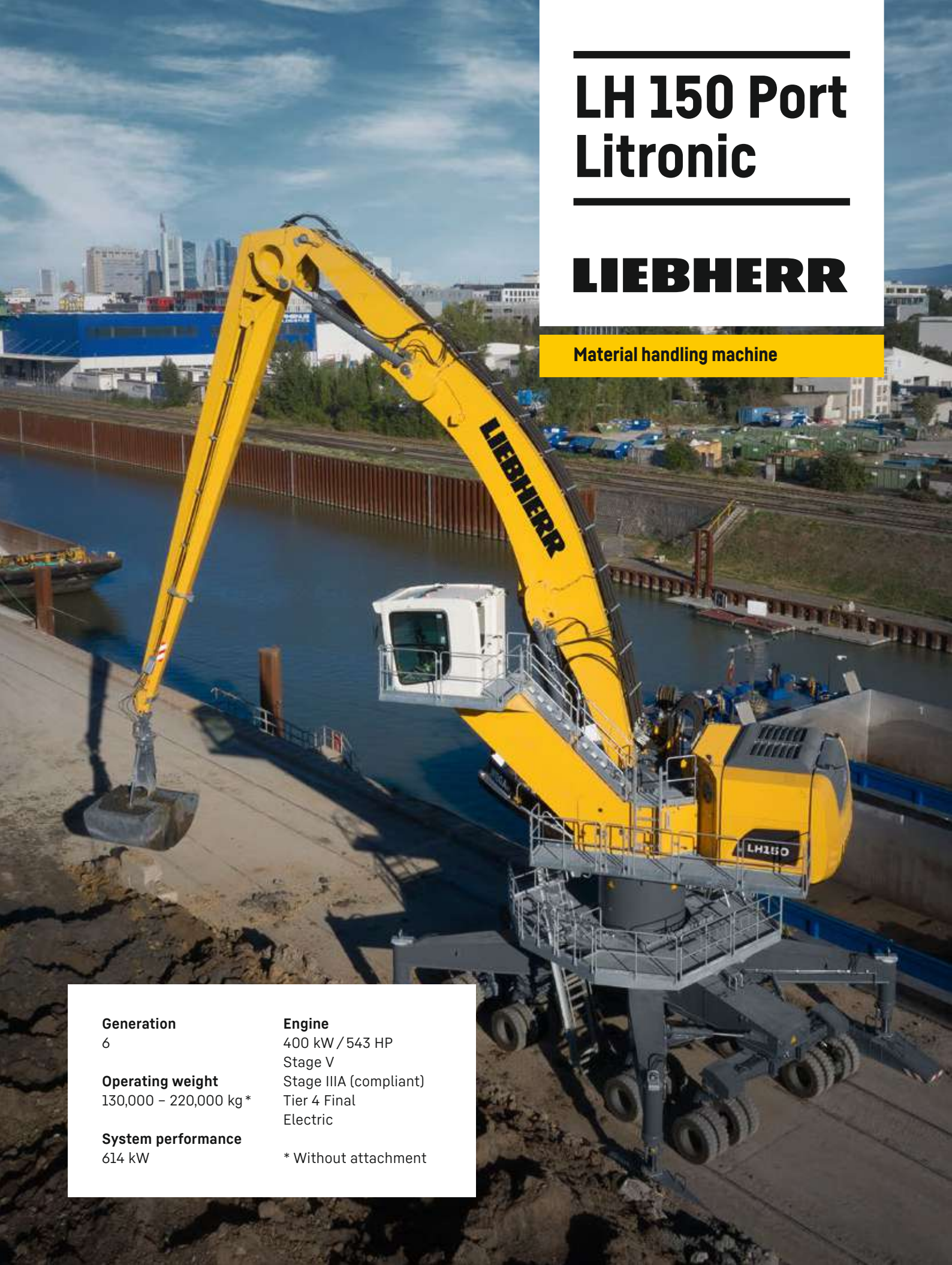

## Performance

Power plus speed –  
Redefined performance

## Economy

Good investment –  
Savings for the long-term

## Reliability

Durability and sustainability –  
Quality down to the last detail

## Comfort

Perfection at a glance –  
When technology is comfortable

## Maintainability

Efficiency bonus –  
Even with maintenance and service



### LH 150 M Port Litronic

**Operating weight**  
130,000 – 150,000 kg \*  
**Engine**  
400 kW / 543 HP  
Stage V  
Stage IIIA (compliant)  
Tier 4 Final  
**System performance**  
614 kW

### LH 150 C Port Litronic

**Operating weight**  
130,000 – 155,000 kg \*  
**Engine**  
400 kW / 543 HP  
Stage V  
Stage IIIA (compliant)  
Tier 4 Final  
Electric  
**System performance**  
614 kW

### LH 150 M High Rise Port Litronic

**Operating weight**  
140,000 – 160,000 kg \*  
**Engine**  
400 kW / 543 HP  
Stage V  
Stage IIIA (compliant)  
Tier 4 Final  
**System performance**  
614 kW





**LH 150 C High Rise Port  
Litronic**

**Operating weight**  
135,000 – 165,000 kg\*

**Engine**  
400 kW / 543 HP  
Stage V  
Stage IIIA (compliant)  
Tier 4 Final  
Electric

**System performance**  
614 kW

**LH 150 M Gantry Port  
Litronic**

**Operating weight**  
150,000 – 185,000 kg\*

**Engine**  
400 kW / 543 HP  
Stage V  
Stage IIIA (compliant)  
Tier 4 Final  
Electric

**System performance**  
614 kW

**LH 150 C Gantry Port  
Litronic**

**Operating weight**  
155,000 – 185,000 kg\*

**Engine**  
400 kW / 543 HP  
Stage V  
Stage IIIA (compliant)  
Tier 4 Final  
Electric

**System performance**  
614 kW

**LH 150 T Gantry Port  
Litronic**

**Operating weight**  
180,000 – 220,000 kg\*

**Engine**  
400 kW / 543 HP  
Stage V  
Stage IIIA (compliant)  
Tier 4 Final  
Electric

**System performance**  
614 kW

\* Without attachment

# Well thought out to the last detail

---







#### **Maximum safety**

- Safe and ergonomic access systems as well as optimal service accessibility for maximum safety
- Various camera systems always ensure the perfect overview during operation



#### **Equipment**

- High payloads and long reaches of up to 30 m thanks to enhanced weight design for increased handling capacity
- The weight-optimised equipment, ERC, hoist and stick cylinders are perfectly tailored to the conditions of use



#### **Optimum maintenance accessibility**

- Large, electro-hydraulic maintenance flaps and a walk-in engine compartment allow quick and safe access to all maintenance points

# Convincing in operation



## Performance

### High engine performance

The 8 cylinder Liebherr V engine and the ERC system together gives a total system performance of 614 kW which ensures maximum handling output.

### Unique mobility

The material handling machine is perfectly suited for narrow quays and terminals, thanks to different steering options. The mobile undercarriage of the LH 150 enable easy positioning of the machine due to the very small turning radius and the option of lateral movement. Individual control of each set of wheels is a great advantage, as the operator can position the machine specifically for the task in hand.

### Rapid work cycles

The intuitive machine controls guarantee that the hydraulics are optimally configured for the task at hand. The Positive Control multi-circuit hydraulic system ensures optimum distribution of the pump flow. Speed and power are available whenever they are needed to ensure high handling capacity.

## Economy

### Alternative drive concept

The LH 150 electric machine is also available as an alternative to the conventional diesel drive. The Liebherr electric motor guarantees powerful and dynamic working movements with the lowest possible energy consumption. In addition, the standard frequency converter ensures the necessary flexibility in the respective application. Through its function as a speed controller, sensitive and dynamic working movements and speed are combined.

### Closed hydraulic circuit for the swing mechanism

The closed slewing circuit feeds the braking energy back into the system when the uppercarriage is braked. This simple yet effective feature sets new standards in terms of efficiency and economy.

## Reliability

### Quality and competence

Our experience, understanding of customer needs and the technical implementation of these findings guarantee the success of the product. For decades, Liebherr has been inspirational with its extent of production and system solutions. Key components such as the diesel engine and electric motors, electronic components, slew ring, slew drives and hydraulic cylinders are developed and produced by Liebherr itself. The degree of in-house manufacturing guarantees maximum quality and ensures that components are optimally configured to each other.

### Robust design

All steel components are designed and manufactured by Liebherr. High-strength steel plates configured for the toughest of requirements result in high torsional stiffness and optimum absorption of forces induced for a longer service life.

### Working area limit

The handling machine can be fitted with an optional working area limit for jobs which require such a feature. Every possible dimension can be adjusted for this purpose – height, depth, reach and proximity. This can prevent collisions and the resulting component damage.

## Comfort

### Ergonomic

The latest cab design delivers excellent conditions for healthy, highly concentrated and productive work in maximum comfort. Both the display unit with touchscreen colour display, the controls and Comfort driver's seat are all coordinated to form a perfect ergonomic unit. In addition the ergonomic joysticks allow the machine operation to be both pleasant and precise.

### Excellent all-round vision

The large areas of glass, different versions of cab elevations and the rear and side area monitoring systems provide the operator with an excellent view of their working area and the zone around the machine. This perfect view enhances the operator's safety and ensures that they can handle the machine safely at all times.

### Proportional control

Precision and the fine control of the material handler are particularly important in applications such as ship loading and unloading in bulk goods and cargo. The machine can master this demanding work with ease thanks to its standard proportional control system.

## Maintainability

### Service-based machine design

The service-based machine design guarantees short servicing times, thus minimising maintenance costs. All the service points are positioned in close proximity to one another, are easily accessible from the ground or on catwalks and platforms, and easy to reach thanks to the large, wide-opening service doors. The enhanced service concept places the maintenance points close to each other and reduces their number to a minimum. This means that service work can be completed even more quickly and efficiently.

### Integral maintenance benefits

Maintenance work helps to keep the machine fully functional. However this kind of work leads to machine downtimes which must be minimised. With change intervals of up to 2,000 hours for engine oil and up to 8,000 hours for hydraulic oil, Liebherr has significantly reduced the amount of maintenance and increased the productivity of the material handlers. In addition, central lubrication systems minimise daily maintenance.



# Material handling machine overview

## Equipment

- High lift capacities and long reaches thanks to weight-optimised design for more handling capacity
- Energy recovery cylinder filled with nitrogen for maximum efficiency through less fuel consumption at more handling capacity
- Pipe fracture safety valves on hoist and stick cylinders and retract stick shut-off for maximum safety during every application
- Electro-hydraulic end position control extends the service life of the components
- Quick coupling systems and attachments made by Liebherr for maximum machine capacity utilisation and greater handling performance

## Operator's cab

- Hydraulic cab elevations for always the best view downwards as well as forwards
- Less strain on the operator, workers and reduced environmental pollution due to lower noise emissions
- Optimum visibility thanks to large glass surfaces and standard rear and side area monitoring with camera
- Large-capacity cab with trainer seat offers plenty of space and creates a pleasant feeling of space
- Proportional steering as standard with 4-way joystick for more functionality and greater precision and fine control

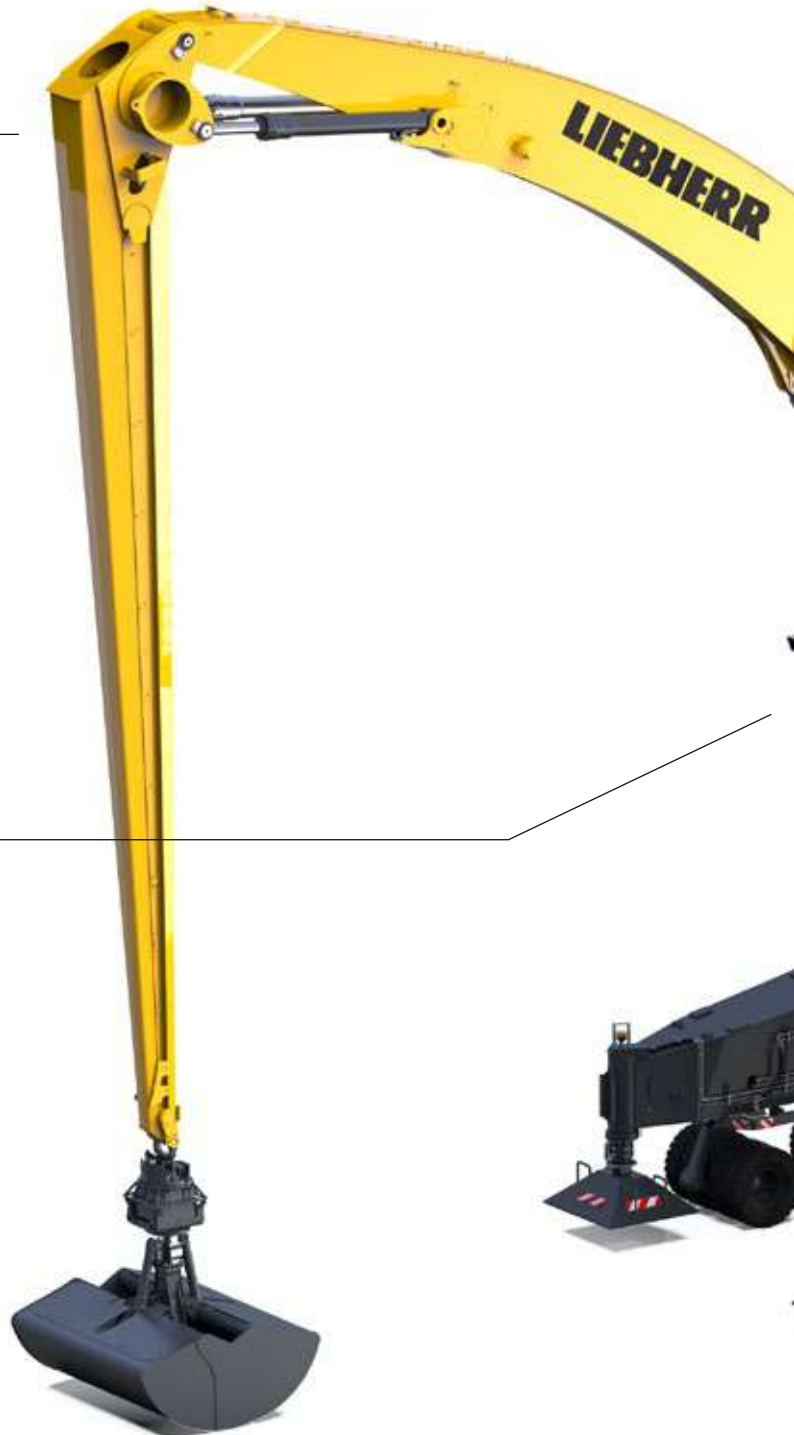





## Uppercarriage

- Positive Control multi-circuit hydraulic system ensures faster working movements with minimum fuel consumption
- 400 kW engine output and high pump flow for fast work cycles, convincing dynamics and maximum handling performance
- Electrical pilot control enables individual settings for the operator and new options such as load torque limitation
- Reduction in operating costs thanks to built-in maintenance advantages and optimum service accessibility
- Unrestricted and easy access to all maintenance points

## Undercarriage

- Maximum mobility and manoeuvrability through various steering modes on the mobile undercarriage
- Large footprint for high stability and maximum lift capacities
- Variety of undercarriage variants for different applications available
- Customer-specific solutions of the gantry undercarriage with regard to clearance width and height

# The perfect solution for every application

## Attachments

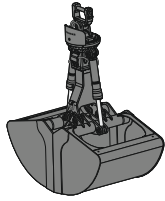

Grab for loose material

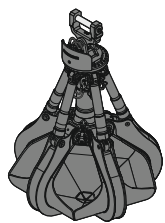

Multi-tine grab



Wood grab

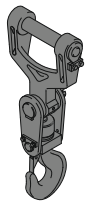

Load hook

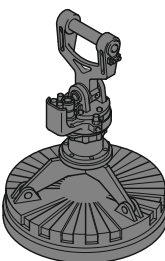

Magnet devices

## Sticks

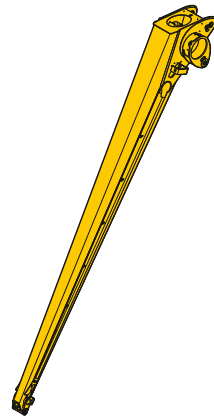

Straight stick

## Booms

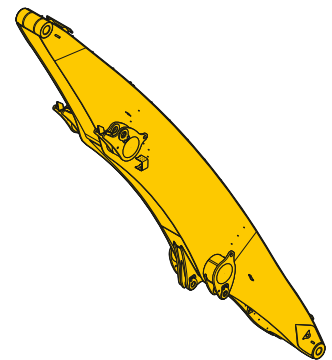

Straight boom

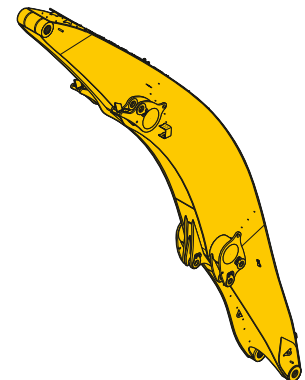

Angled boom



## Cab elevations

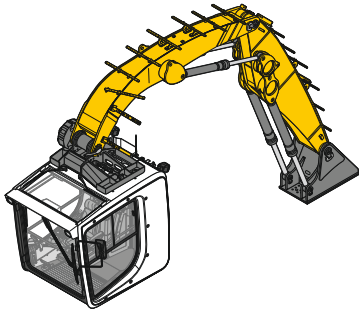

Hydraulic cab elevation

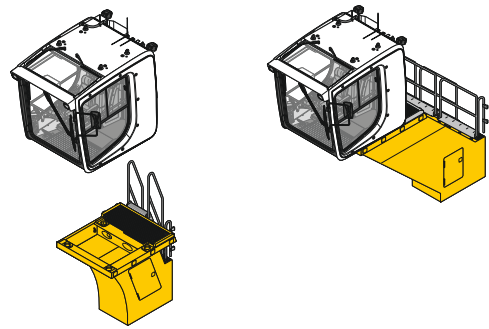

Rigid cab elevation

## Uppercarriage

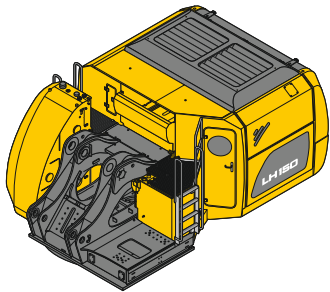

Diesel engine

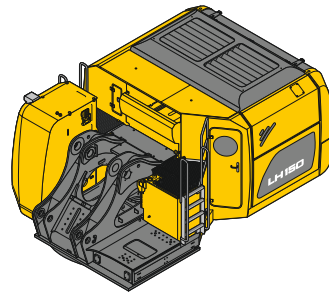

Electric engine

## Undercarriage



Turret Elevations

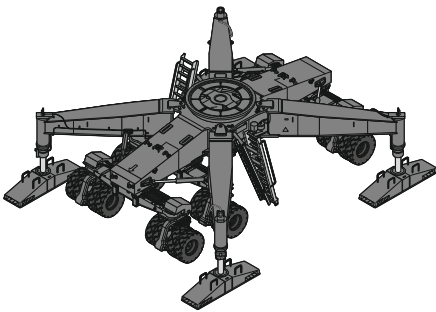

Mobile

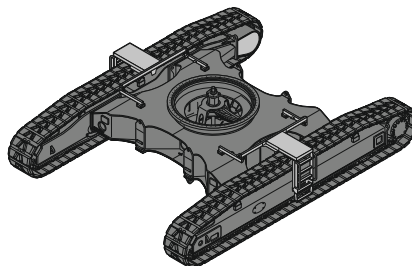

Crawler

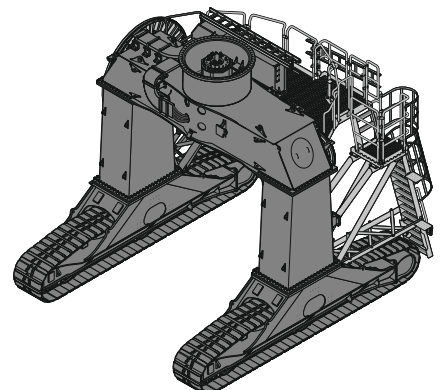

Gantry (Mobile, Crawler, Track)

# Technical data



## Diesel engine

<b>Rating per ISO 9249</b>	400 kW (543 HP) at 1,700 RPM
<b>Model</b>	Liebherr D9508
<b>Type</b>	8 cylinder V-engine
<b>Bore / Stroke</b>	128 / 157 mm
<b>Displacement</b>	16.16 l
<b>Engine operation</b>	4-stroke diesel Common-Rail Turbo-charged and after-cooled Reduced emissions
<b>Air cleaner</b>	Dry-type air cleaner with pre-cleaner, primary and safety elements
<b>Engine idling</b>	Sensor controlled
<b>Electrical system</b>	
<b>Voltage</b>	24 V
<b>Batteries</b>	4 x 180 Ah / 12 V
<b>Alternator</b>	Three-phase current 28 V / 180 A
<b>Stage V</b>	
<b>Harmful emissions values</b>	According to regulation (EU) 2016/1628
<b>Emission control</b>	Liebherr-SCR Filter technology
<b>Fuel tank</b>	2,840 l
<b>Urea tank</b>	180 l
<b>Stage IIIA (compliant)</b>	
<b>Harmful emissions values</b>	In accordance with ECE-R.96 Power Band H
<b>Fuel tank</b>	2,840 l
<b>Tier 4 Final</b>	
<b>Harmful emissions values</b>	In accordance with 40CFR1039 (EPA) / 13CCR (CARB)
<b>Emission control</b>	Liebherr-SCR technology
<b>Fuel tank</b>	2,840 l
<b>Urea tank</b>	180 l



## Electric motor

<b>Rating</b>	400 kW at 1,700 RPM
<b>Model</b>	Liebherr KGF1391
<b>Type</b>	Three-phase squirrel cage motor
<b>Secondary electric motor</b>	Electric motor auxiliary equipment (air-conditioning compressor, alternator 24 V) 15 kW
<b>Electrical system energy supply</b>	Liebherr drive components and control cabinets for uppercarriage and undercarriage Liebherr frequency converter fed drive system Heavy-duty version
<b>Manufacturer</b>	Liebherr
<b>Supply voltage</b>	
<b>Low voltage</b>	380-690 V
<b>High voltage</b>	2.14-20 kV
<b>Frequency</b>	50 / 60 Hz
<b>Engine idling</b>	Sensor controlled
<b>Electrical system</b>	Battery-assisted Control system, lighting, diagnostics system
<b>Voltage</b>	24 V
<b>Batteries</b>	2 x 180 Ah / 12 V
<b>Alternator</b>	Three-phase current 28 V / 140 A



## Cooling system

<b>Diesel engine</b>	Water-cooled Cooling system, consisting of a cooling unit for water and charge air and a 2 <sup>nd</sup> cooler for hydraulic oil, each with an infinitely variable, thermostatically controlled fan drive system
<b>Electric motor</b>	Air-cooled Cooling system for hydraulic oil with an infinitely variable, thermostatically controlled fan drive system Frequency converter water-cooled



## Hydraulic controls

<b>Power distribution</b>	Via control valves with integrated safety valves, simultaneous actuation of chassis and equipment. Swing drive in separate closed circuit
<b>Servo circuit</b>	
<b>Equipment and swing</b>	With electro-hydraulic pilot control and proportional joystick levers
<b>Chassis</b>	with electro-hydraulic pilot control and an additional proportional joystick lever
<b>Additional functions</b>	
<b>Proportional control</b>	Proportionally acting transmitters on the joysticks for additional hydraulic functions



## Hydraulic system

<b>Hydraulic pump</b>	
<b>For equipment and travel drive</b>	4 Liebherr axial piston variable displacement pumps
<b>Max. flow</b>	4 x 278 l/min.
<b>Max. pressure</b>	350 bar
<b>For swing drive</b>	Reversible axial piston variable displacement pump, closed-loop circuit
<b>Max. flow</b>	455 l/min.
<b>Max. pressure</b>	260 bar
<b>Hydraulic pump regulation and control</b>	Positive Control multi-circuit hydraulic system for independent and demand controlled dosing via the hydraulic pumps; sensor-controlled
<b>Hydraulic tank</b>	860 l
<b>Hydraulic system</b>	1,650-1,700 l (depending on undercarriage version)
<b>Filtration</b>	3 main return filters with integrated partial micro filtration (5 µm), 1 high pressure filter for each main pump
<b>MODE selection</b>	Adjustment of engine and hydraulic performance via a mode pre-selector to match application, e.g. for especially economical and environmentally friendly operation or for maximum material handling and heavy-duty jobs
<b>S (Sensitive)</b>	Mode for precision work and lifting through very sensitive movements
<b>E (Eco)</b>	Mode for especially economical and environmentally friendly operation
<b>P (Power)</b>	Mode for high performance with low fuel consumption
<b>P+ (Power-Plus)</b>	Mode for highest performance and for very heavy duty applications, suitable for continuous operation



## Swing drive

<b>Drive</b>	Liebherr axial piston motor in a closed system, Liebherr planetary reduction gear
<b>Swing ring</b>	Liebherr, sealed race ball bearing swing ring, internal teeth
<b>Swing speed</b>	0-5.5 RPM stepless
<b>Swing torque</b>	260 kNm
<b>Holding brake</b>	Wet multi-disc (spring applied, pressure released)
<b>Option</b>	Slewing gear brake Comfort





## Cab

<b>Cab</b>	Spacious operator cabin with profiled design, excellent view on working area, access from behind, fixed front, roof and base panel made of bullet proof glass, front screen with electrical heating, shock-absorbing suspension, sound damping insulating, sliding window on left side, sun shadings, folding seat for instructor
<b>Operator's seat Comfort</b>	Air cushioned operator's seat with 3D-adjustable armrests, headrest, lap belt, seat heater, adjustable seat cushion inclination and length, lockable horizontal suspension, automatic weight adjustment, adjustable suspension stiffness, pneumatic lumbar vertebrae support and passive seat climatization with active coal
<b>Operator's seat Premium (Option)</b>	In addition to operator's seat comfort: active electronic weight adjustment (automatic readjustment), pneumatic low frequency suspension and active seat climatization with active coal and ventilator
<b>Arm consoles</b>	Joysticks with control consoles and swivel seat
<b>Operation and displays</b>	Large high-resolution operating unit, self-explanatory, colour display with touchscreen, video-compatible, numerous setting, control and monitoring options, e.g. air conditioning control, fuel consumption respectively energy consumption, machine and attachment parameters
<b>Air-conditioning</b>	Automatic air-conditioning, recirculated air function, fast de-icing and demisting at the press of a button, air vents can be operated via a menu; recirculated air and fresh air filters can be easily replaced and are accessible from the outside; heating-cooling unit, designed for extreme outside temperatures, sensors for solar radiation, inside and outside temperatures
Diesel engine	Automatic air-conditioning, recirculated air function, fast de-icing and demisting at the press of a button, air vents can be operated via a menu; recirculated air and fresh air filters can be easily replaced and are accessible from the outside; heating-cooling unit, designed for extreme outside temperatures, sensors for solar radiation, inside and outside temperatures
Electric motor	In addition to diesel engine: stationary air conditioning function with external climate condenser - controlled by a weekly timer
Refrigerant	R134a
Global warming potential	1,430
Quantity at 25 °C*	1,700-2,500 g
CO <sub>2</sub> equivalent*	2.431-3.575 t
<b>Vibration emission**</b>	
Hand / arm vibrations	< 2.5 m/s <sup>2</sup>
Whole-body vibrations	< 0.5 m/s <sup>2</sup>
Measuring inaccuracy	According with standard EN 12096:1997



## Equipment

<b>Type</b>	Weight-optimised design for bulk and general cargo handling at optimal handling capacity. Complex and stable mountings of equipment and cylinders
<b>Hydraulic cylinders</b>	Liebherr cylinders with special sealing and guide system and, depending on cylinder type, shock absorption
<b>Energy recovering cylinder</b>	Liebherr gas cylinder with special sealing and control system
<b>Bearings</b>	Sealed, low maintenance

\* depending on configuration

\*\* for risk assessment according to 2002/44/EC see ISO/TR 25398:2006



## Undercarriage

<b>Mobile</b>	
Versions	Standard, High Rise
Drive	One axle drive per drive axle with Liebherr axial piston motor and functional brake valve on both sides
Travel speed	0-4.2 km/h stepless (creeper speed)
Joystick steering	0-7.8 km/h stepless
Axles	Wheelsets with suspended 40 t axles, with slewing drive rotating around the vertical axis, hydraulic cylinder for leveling
Position of wheelsets	6 steering axles, 2 powered and braked, for leveling and axle load distribution, interconnected by hydraulic
Option	8 steering axles, 2 powered and braked
Steering programs	Front wheel, rear wheel and all-wheel steering, move to the side in crab steering possible, turning on the spot
Service brake	Two circuit travel brake system with accumulator
Holding brake	Wet multi-disc (spring applied, pressure released)
Stabilization	X-shaped 4 point support with 4 folding arms, one vertically positioned support cylinder per folding arm, support plates with ball-and-socket joint, removable
<b>Crawler</b>	
Versions	SW, High Rise, Gantry
Drive	Liebherr compact planetary reduction gear with Liebherr axial piston motor per side of undercarriage
Travel speed	0-1.7 km/h stepless (creeper speed) 0-3.9 km/h stepless
Brake	Functional brake valves on both sides
Holding brake	Wet multi-disc (spring applied, pressure released)
Track pads	Flat
Tracks	Sealed and greased
<b>Rail-mounted Gantry</b>	
Chassis	Rail travel drive designed for the respective load per undercarriage corner
Drive	Compact planetary reduction gear with axial piston motor per rail travel drive
Brake	Functional brake valves on both sides
Holding brake	Per rail travel drive wet multi-disc (spring applied, pressure released)
Storm brakes (Option)	Different designs



## Complete machine

<b>Lubrication</b>	Liebherr central lubrication system for uppercarriage and equipment, automatically
Mobile (Option)	Liebherr central lubrication system for undercarriage, automatically
<b>Steps system</b>	Safe and durable access system with anti-slip steps; main components hot-galvanised
<b>Noise emission</b>	
ISO 6396 (Stage V)	71 dB(A) = L <sub>PA</sub> (inside cab)
2000/14/EC (Stage V)	108 dB(A) = L <sub>WA</sub> (surround noise)
ISO 6396 (Stage IIIA compliant)	71 dB(A) = L <sub>PA</sub> (inside cab)
2000/14/EC (Stage IIIA compliant)	109 dB(A) = L <sub>WA</sub> (surround noise)
ISO 6396 (Tier 4 Final)	71 dB(A) = L <sub>PA</sub> (inside cab)
2000/14/EC (Tier 4 Final)	108 dB(A) = L <sub>WA</sub> (surround noise)
ISO 6396 (Electric)	71 dB(A) = L <sub>PA</sub> (inside cab)
2000/14/EC (Electric)	108 dB(A) = L <sub>WA</sub> (surround noise)

# LH 150 M – Dimensions

## Port

### Cab elevation LFC 250

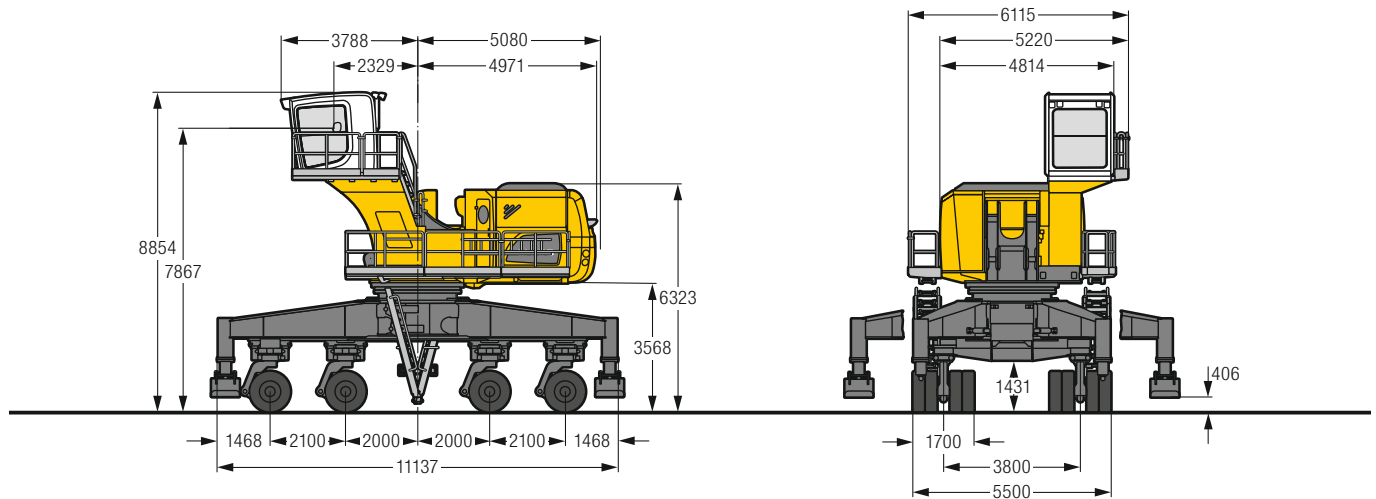

# LH 150 M – Cab elevation

## Cab elevation LFC 350 (rigid elevation)

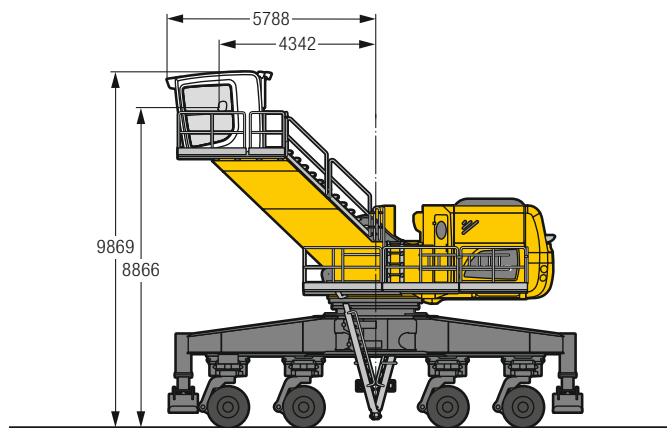

Tyres 12.00-20



# LH 150 M HR – Dimensions

## Port

### Cab elevation LFC 250

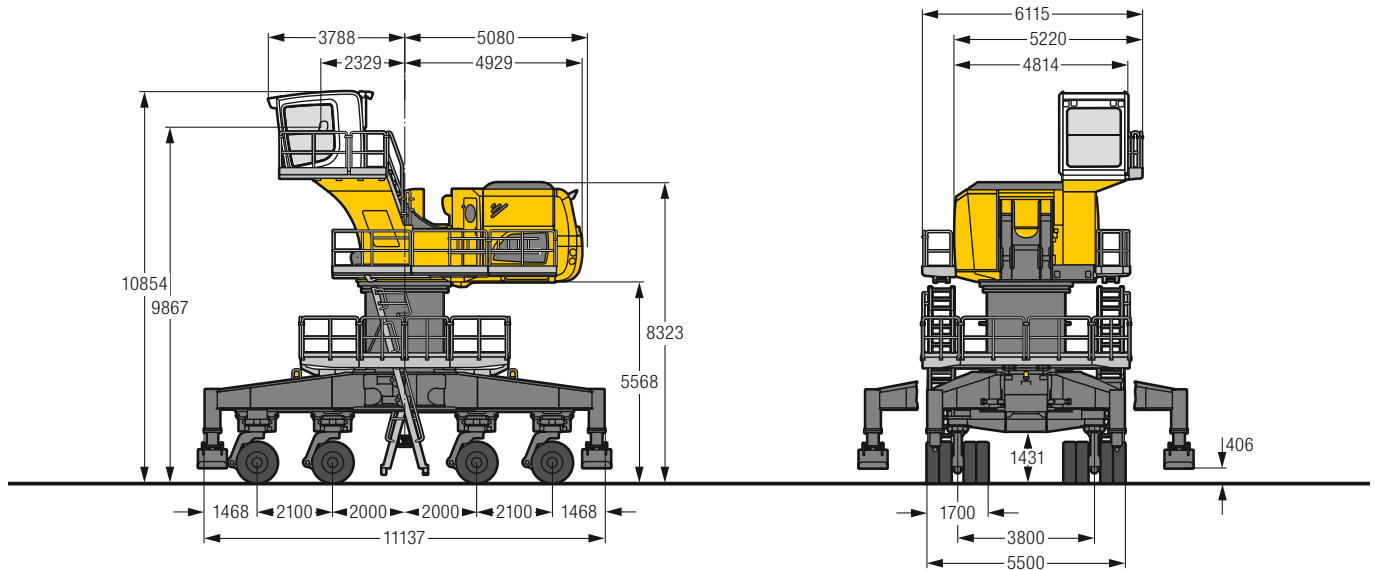

# LH 150 M HR – Choice of cab elevation

### Cab elevation LFC 350 (rigid elevation)

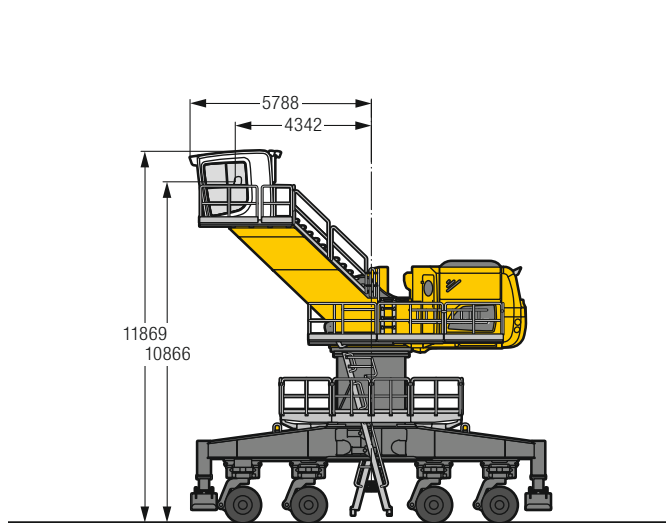

### Cab elevation LHC-D 1090 T (hydraulic elevation)

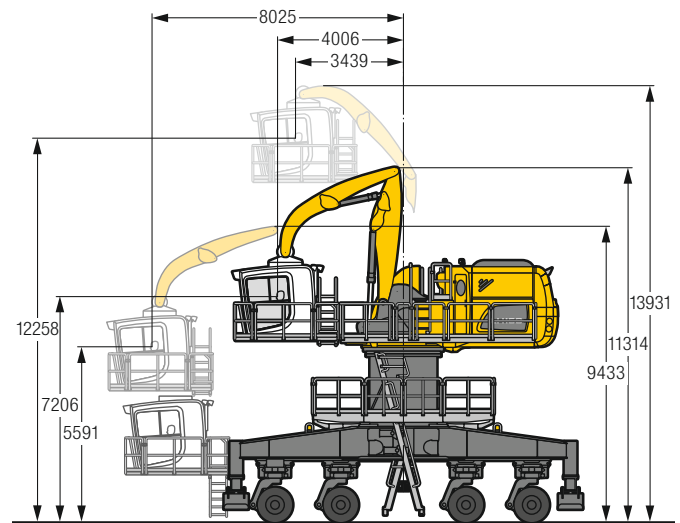

The hydraulically adjustable cab allows the driver, that he can choose his field of view freely and at any time within the stroke.

# LH 150 M – Dimensions Undercarriage

## Port

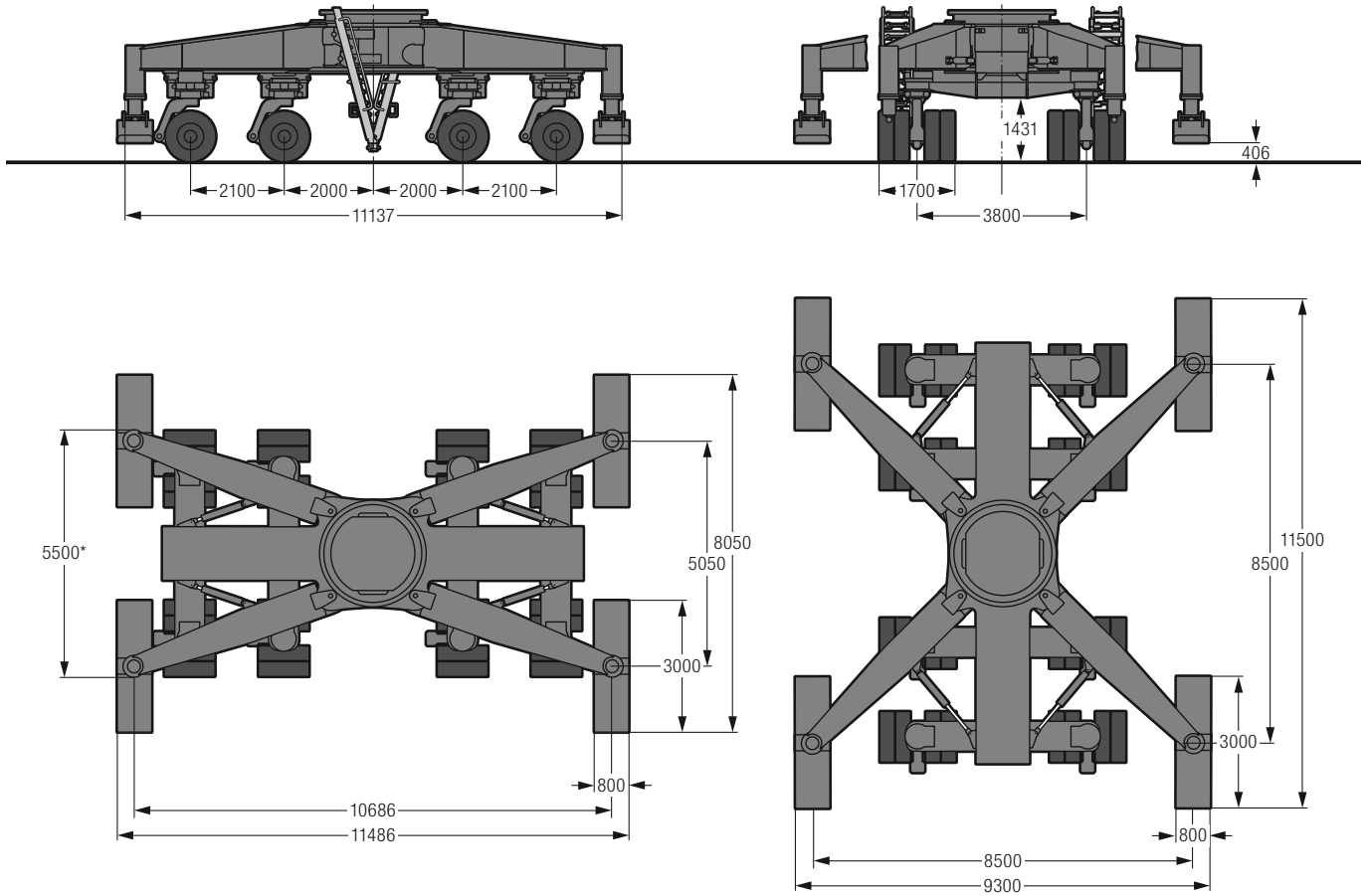

\* with removed support plates



# LH 150 M Gantry – Dimensions

## Port

### Cab elevation LFC 250

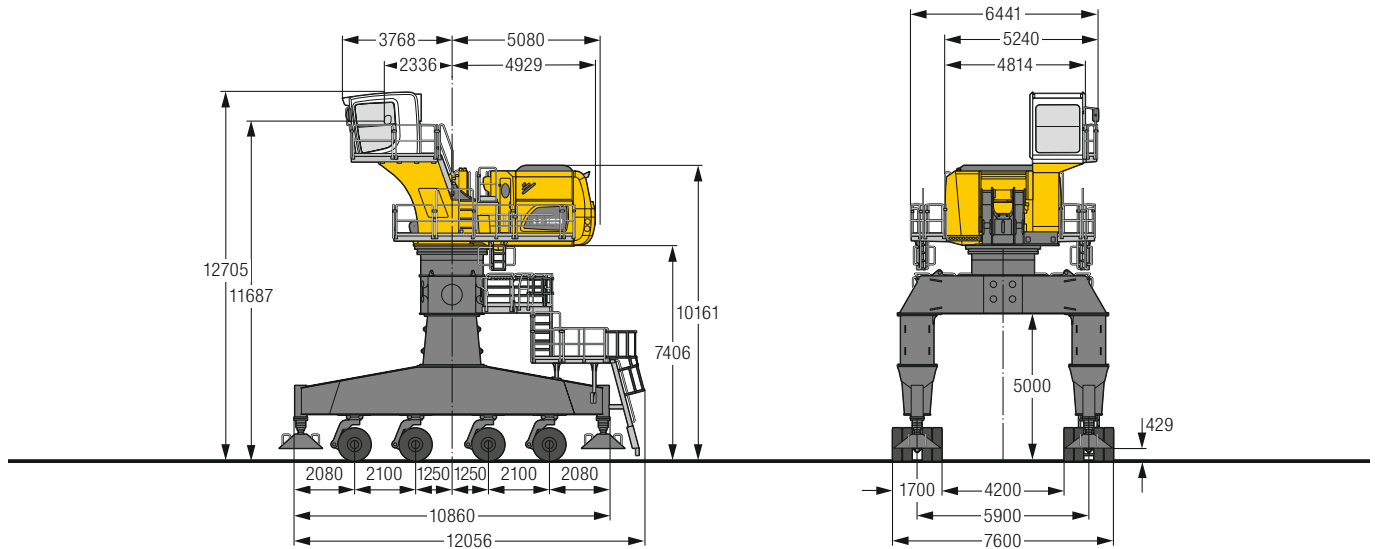

# LH 150 M Gantry – Choice of cab elevation

### Cab elevation LFC 350 (rigid elevation)

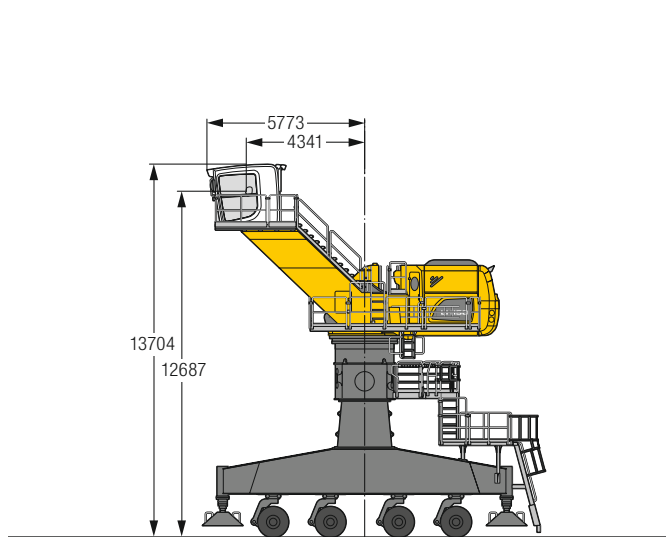

### Cab elevation LHC-D 1090 T (hydraulic elevation)

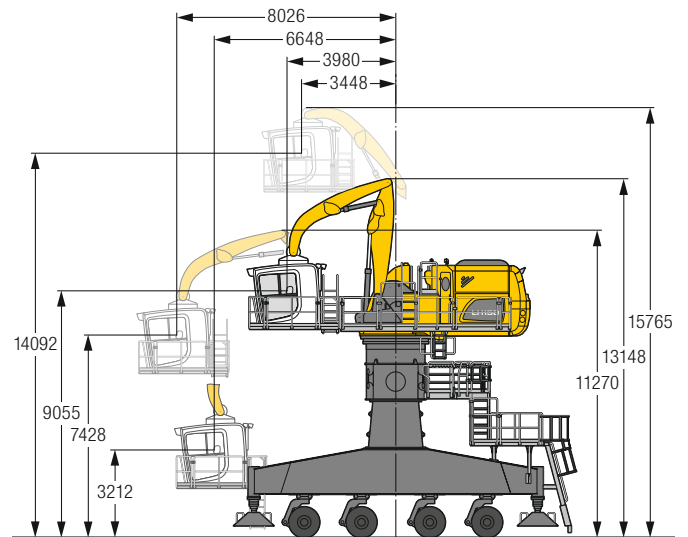

The hydraulically adjustable cab allows the driver, that he can choose his field of view freely and at any time within the stroke.

# LH 150 C – Dimensions

## Port

### Cab elevation LFC 250

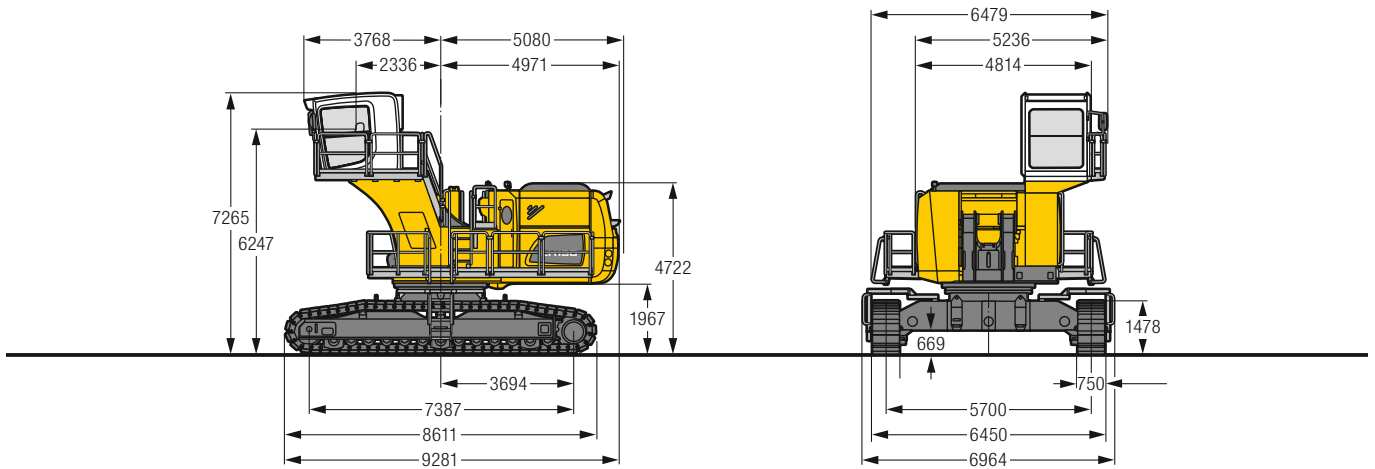

# LH 150 C – Cab elevation

## Cab elevation LFC 350 (rigid elevation)

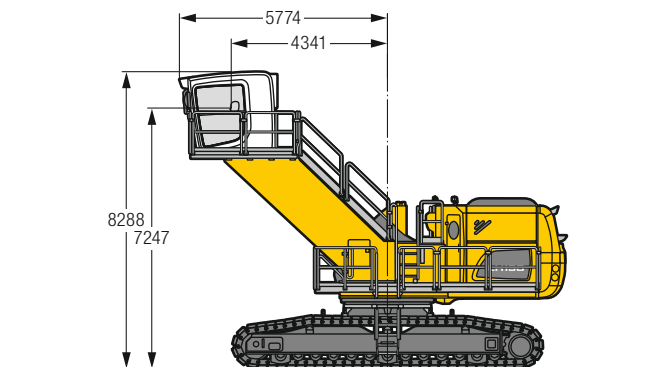

# LH 150 C HR – Dimensions

## Port

### Cab elevation LFC 250

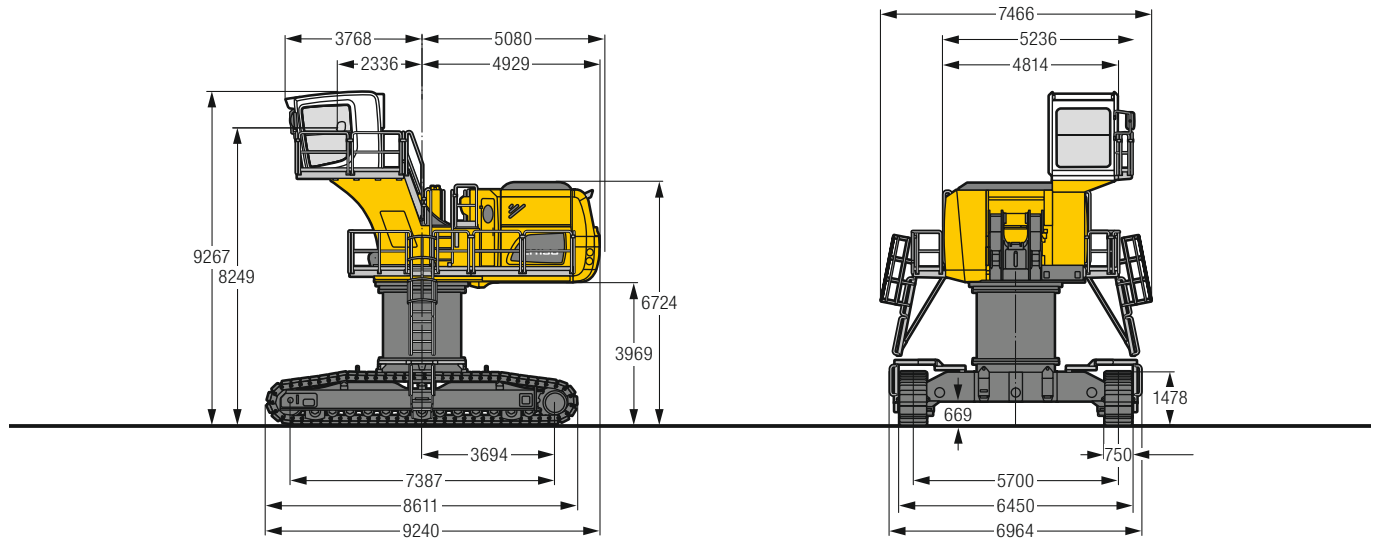

# LH 150 C HR – Choice of cab elevation

### Cab elevation LFC 350 (rigid elevation)

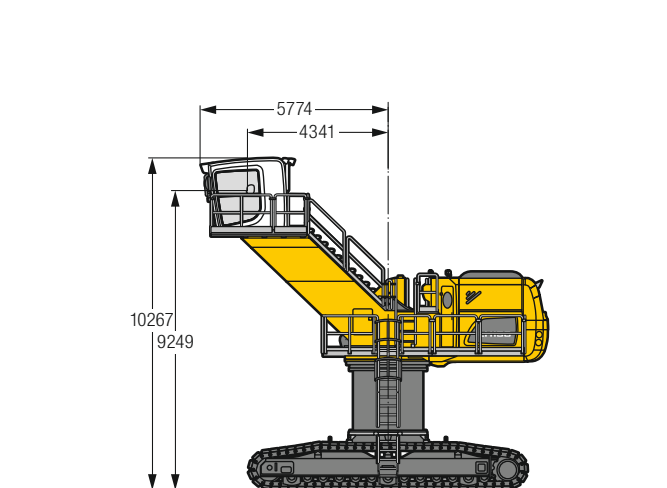

### Cab elevation LHC-D 1090 T (hydraulic elevation)

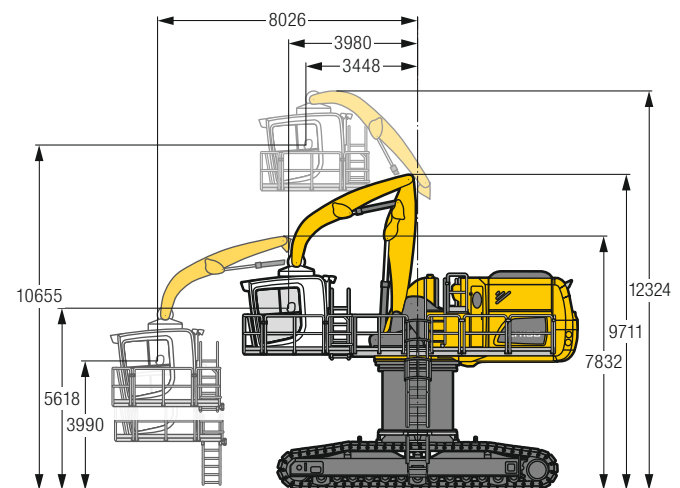

The hydraulically adjustable cab allows the driver, that he can choose his field of view freely and at any time within the stroke.



# LH 150 C Gantry – Dimensions

## Port

### Cab elevation LFC 250

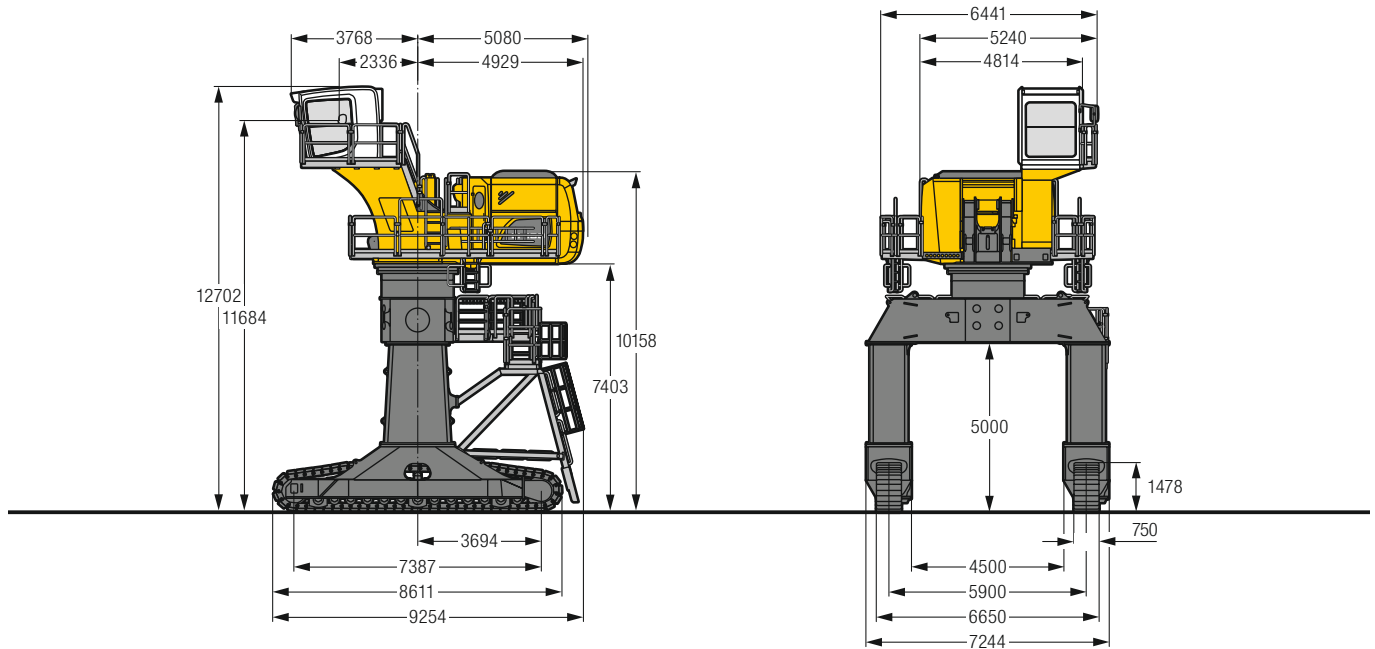

# LH 150 C Gantry – Choice of cab elevation

### Cab elevation LFC 350 (rigid elevation)

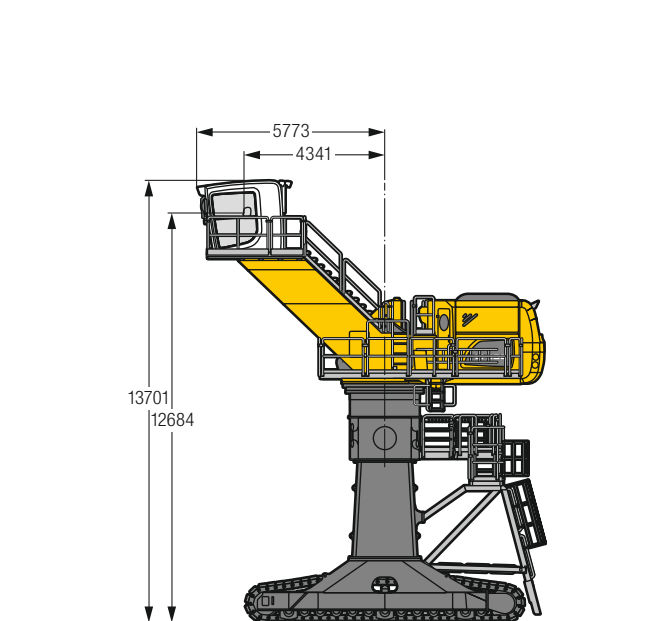

### Cab elevation LHC-D 1090 T (hydraulic elevation)

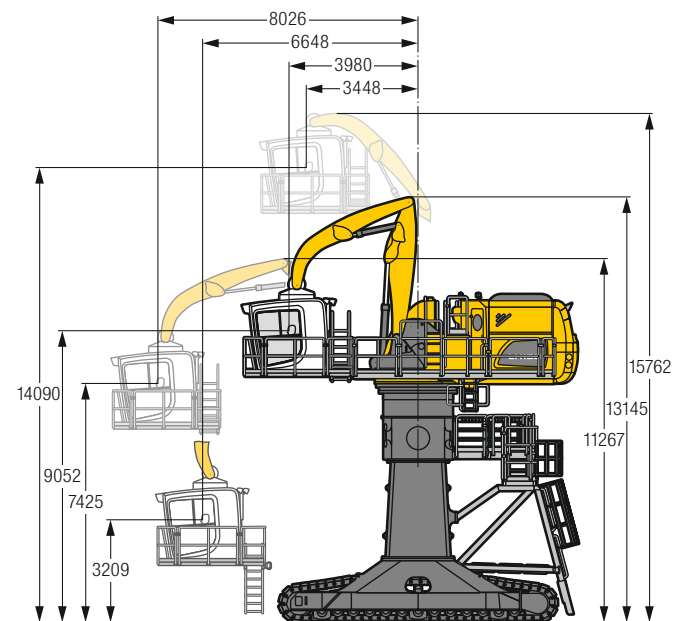

The hydraulically adjustable cab allows the driver, that he can choose his field of view freely and at any time within the stroke.

## Kinematic variant 2A

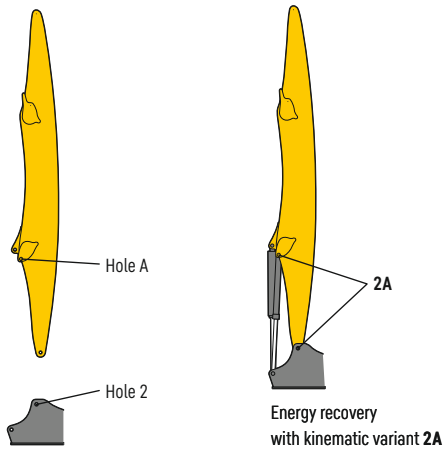

## Kinematic variant 2D / 2C

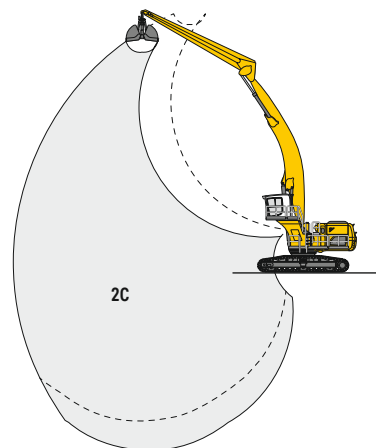
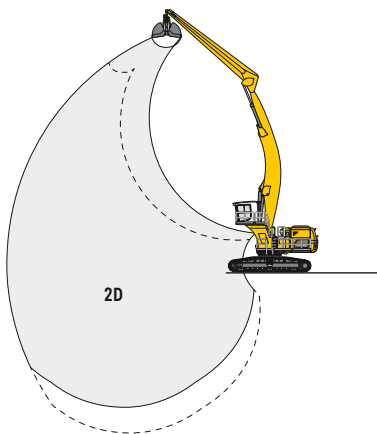
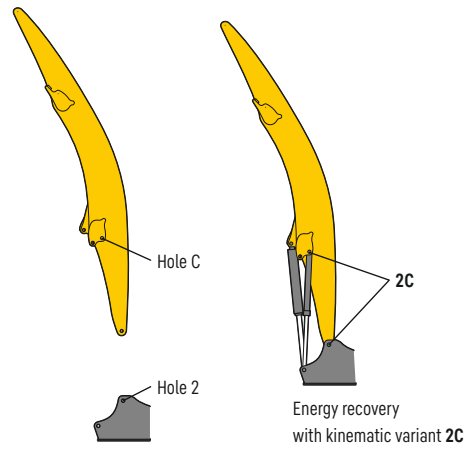
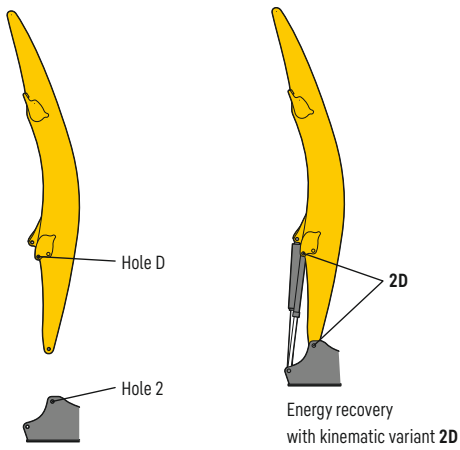

Altered range curve with additional reach depth, e.g. for unloading from ships

# LH 150 M – Equipment AG24

## Port – Kinematic 2D

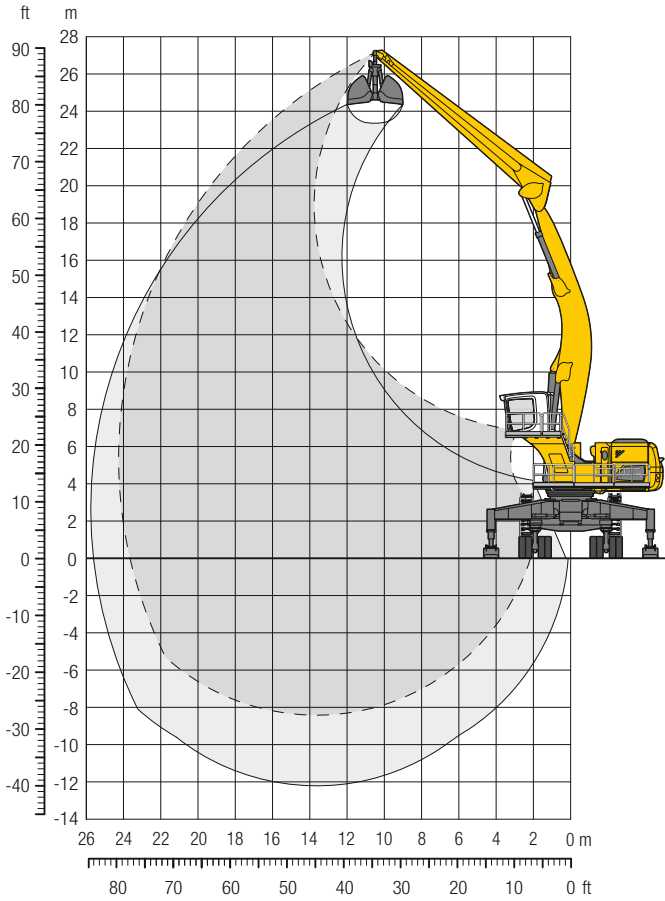

### Dimensions

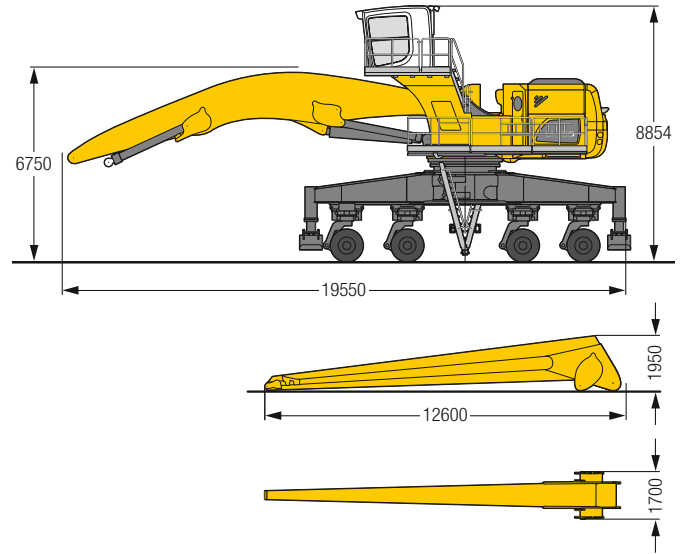

### Operating weight

The operating weight includes the basic machine with 4 point outriggers, rigid cab elevation, 32 solid tyres, angled boom 13.50m, straight stick 12.00m and grab for loose material GMZ 120 / 8.00 m<sup>3</sup>.

Weight 151,100kg

m	Undercarriage	6.0m		9.0m		12.0m		15.0m		18.0m		21.0m		24.0m		27.0m		30.0m		31.5m		m	
		4 pt. outriggers down	4 pt. outriggers down	4 pt. outriggers down	4 pt. outriggers down	4 pt. outriggers down	4 pt. outriggers down	4 pt. outriggers down	4 pt. outriggers down	4 pt. outriggers down	4 pt. outriggers down	4 pt. outriggers down	4 pt. outriggers down	4 pt. outriggers down	4 pt. outriggers down	4 pt. outriggers down	4 pt. outriggers down	4 pt. outriggers down	4 pt. outriggers down	4 pt. outriggers down	4 pt. outriggers down	4 pt. outriggers down	4 pt. outriggers down
27.0	4 pt. outriggers down							13.3*	13.3*											14.6*	14.6*	10.9	
24.0	4 pt. outriggers down							16.1*	16.1*	12.5*	12.5*									12.1*	12.1*	15.5	
21.0	4 pt. outriggers down							16.0*	16.0*	14.4*	14.4*									11.1*	11.1*	18.5	
18.0	4 pt. outriggers down							16.3*	16.3*	14.5*	14.5*									10.6*	10.6*	20.7	
15.0	4 pt. outriggers down							19.8*	19.8*	14.5*	14.5*	13.2*	13.2*							10.4*	10.4*	22.2	
12.0	4 pt. outriggers down					19.8*	19.8*	16.9*	16.9*	14.8*	14.8*	13.3*	13.3*							10.4*	10.4*	23.3	
9.0	4 pt. outriggers down			27.0*	27.0*	21.3*	21.3*	17.8*	17.8*	15.4*	15.4*	13.6*	13.6*							10.6*	10.6*	23.9	
6.0	4 pt. outriggers down	46.0*	46.0*	30.5*	30.5*	23.1*	23.1*	18.8*	18.8*	16.0*	16.0*	13.9*	13.9*	11.7*	11.7*					11.1*	11.1*	24.1	
3.0	4 pt. outriggers down	21.2*	21.2*	33.6*	33.6*	24.8*	24.8*	19.8*	19.8*	16.5*	16.5*	14.2*	14.2*							11.8*	11.8*	24.0	
0	4 pt. outriggers down	16.3*	16.3*	35.3*	35.3*	25.9*	25.9*	20.4*	20.4*	16.8*	16.8*	14.1*	14.1*							11.9*	11.9*	23.5	
-3.0	4 pt. outriggers down	17.1*	17.1*	32.6*	32.6*	25.8*	25.8*	20.3*	20.3*	16.5*	16.5*	13.3*	13.3*							11.5*	11.5*	22.5	
-6.0	4 pt. outriggers down			31.3*	31.3*	23.9*	23.9*	18.8*	18.8*	14.9*	14.9*									11.7*	11.7*	20.5	
-9.0	4 pt. outriggers down																						

Height Can be slewed through 360° In longitudinal position of undercarriage Max. reach \* Limited by hydr. capacity

The lift capacities on the stick end without attachment are stated in metric tons (t) and are valid on a firm, level supporting surface with blocked oscillating axle. These capacities can be slewed through 360° with the undercarriage in the transverse position. Capacities in the longitudinal position of the undercarriage (±15°) are specified over the rigid axle with the stabilizers down. Indicated loads based on the ISO 10567 standard and do not exceed 75% of tipping or 87% of hydraulic capacity. The lift capacity values indicated are attained at the corresponding operating temperature. This operating temperature is ensured by continuous movement of the boom. Weights of fitted attachments (grabs, load hooks, etc.) and load accommodation attachment are to be deducted from the lift capacity values. The lift capacity of the unit is limited by its stability, the lifting capability of the hydraulic elements, or the maximum permissible lifting capacity of the load hook. In accordance with the harmonised European Standard EN 474-5, hydraulic excavators used for lifting operations must be equipped with pipe fracture safety valves, an overload warning device, a load hook and a lift capacity chart.



# LH 150 C HR – Equipment AG27

## Port – Kinematic 2D

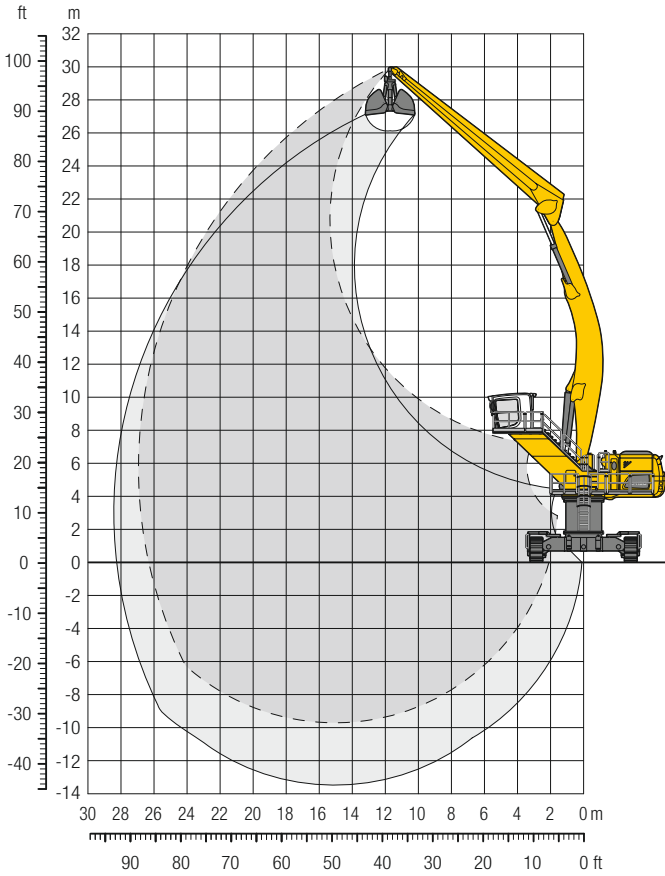

### Dimensions

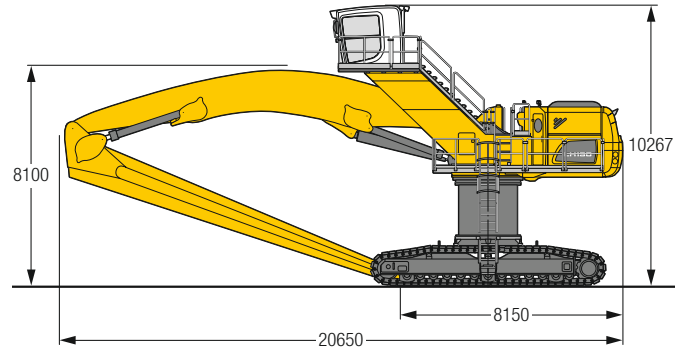

### Operating weight and ground pressure

The operating weight includes the basic machine with turret 2,000 mm, rigid cab elevation, angled boom 15.00 m, straight stick 13.50 m and grab for loose material GMZ 120 / 8.00 m<sup>3</sup>.

Weight	150,600 kg
Pad width	750 mm
Ground pressure	on request

m	Undercarriage	6.0m		9.0m		12.0m		15.0m		18.0m		21.0m		24.0m		27.0m		30.0m		31.5m		Max. reach		m
		SW	SW	SW	SW	SW	SW	SW	SW	SW	SW	SW	SW	SW	SW	SW	SW	SW	SW	SW	SW	SW	SW	
27.0	SW							13.2*	13.2*													10.8*	10.8*	16.4
24.0	SW							15.1*	15.1*	12.9*	12.9*											9.8*	9.8*	19.7
21.0	SW									13.1*	13.1*	11.7*	11.7*									9.3*	9.3*	22.2
18.0	SW									13.1*	13.1*	11.7*	11.7*									9.0*	9.0*	24.0
15.0	SW							15.3*	15.3*	13.3*	13.3*	11.8*	11.8*	10.7*	10.7*							8.9*	8.9*	25.3
12.0	SW							15.8*	15.8*	13.6*	13.6*	12.0*	12.0*	10.8*	10.8*							9.0*	9.0*	26.2
9.0	SW			26.2*	26.2*	20.2*	20.2*	16.6*	16.6*	14.1*	14.1*	12.3*	12.3*	10.9*	10.9*							9.2*	9.2*	26.7
6.0	SW	44.3*	44.3*	29.0*	29.0*	21.7*	21.7*	17.4*	17.4*	14.6*	14.6*	12.6*	12.6*	11.1*	11.1*							9.6*	9.6*	26.9
3.0	SW	15.6*	15.6*	31.4*	31.4*	23.0*	23.0*	18.2*	18.2*	15.1*	15.1*	12.9*	12.9*	11.1*	11.1*							9.7*	9.7*	26.8
0	SW	12.5*	12.5*	29.1*	29.1*	23.8*	23.8*	18.7*	18.7*	15.4*	15.4*	13.0*	13.0*	11.0*	11.0*							9.5*	9.5*	26.3
-3.0	SW	13.3*	13.3*	23.8*	23.8*	23.8*	23.8*	18.7*	18.7*	15.3*	15.3*	12.7*	12.7*	10.5*	10.5*							9.2*	9.2*	25.5
-6.0	SW	14.9*	14.9*	23.3*	23.3*	22.5*	22.5*	17.9*	17.9*	14.5*	14.5*	11.7*	11.7*	8.9*	8.9*							8.6*	8.6*	24.2
-9.0	SW					19.4*	19.4*	15.5*	15.5*	12.4*	12.4*											11.0*	11.0*	19.4

Height 
 Can be slewed through 360° 
 In longitudinal position of undercarriage 
 Max. reach 
 \* Limited by hydr. capacity

The lift capacities on the stick end without attachment are stated in metric tons (t) and can be slewed through 360° on a firm, level supporting surface. Capacities are valid for 750 mm wide flat pads. Indicated loads based on the ISO 10567 standard and do not exceed 75% of tipping or 87% of hydraulic capacity. The lift capacity values indicated are attained at the corresponding operating temperature. This operating temperature is ensured by continuous movement of the boom. Weights of fitted attachments (grabs, load hooks, etc.) and load accommodation attachment are to be deducted from the lift capacity values. The lift capacity of the unit is limited by its stability, the lifting capability of the hydraulic elements, or the maximum permissible lifting capacity of the load hook. In accordance with the harmonised European Standard EN 474-5, hydraulic excavators used for lifting operations must be equipped with pipe fracture safety valves, an overload warning device, a load hook and a lift capacity chart.

# LH 150 M HR – Equipment AG30

## Port – Kinematic 2D

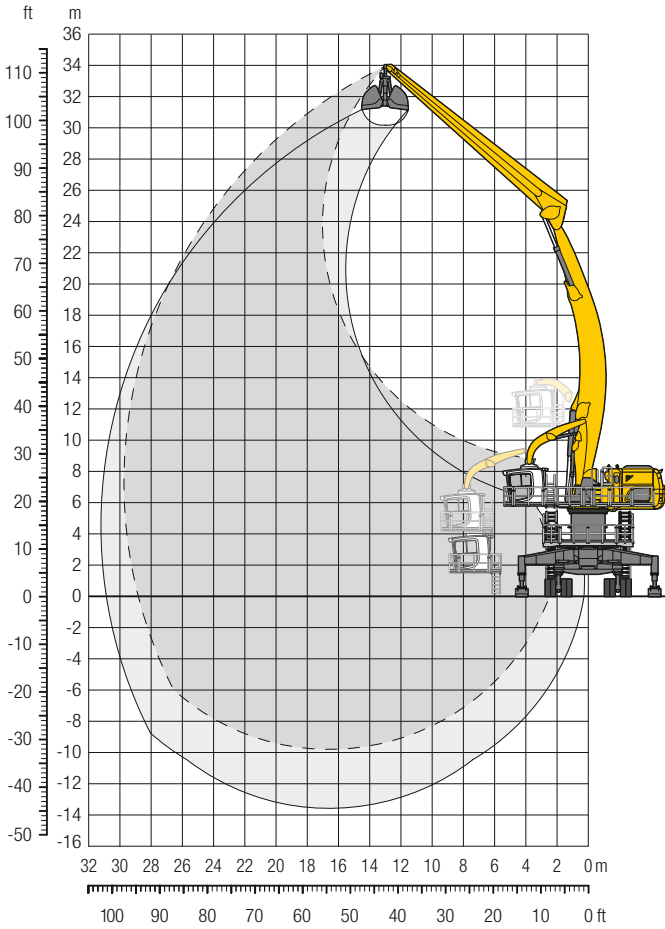

### Dimensions

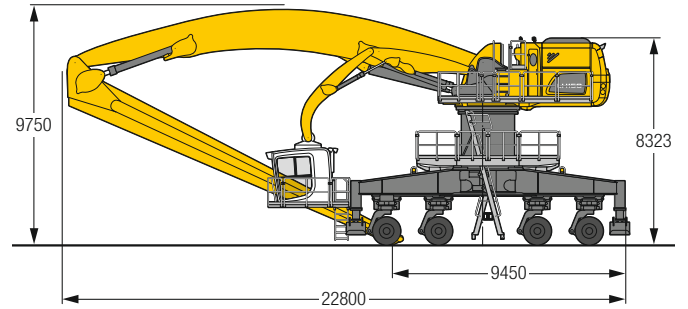

### Operating weight

The operating weight includes the basic machine with 4 point outriggers, turret 2,000 mm, hydr. cab elevation, 32 solid tyres, angled boom 16.50 m, straight stick 15.00 m and grab for loose material GMZ 120 / 8.00 m<sup>3</sup>.

Weight 169,300 kg

m	Undercarriage	6.0m		9.0m		12.0m		15.0m		18.0m		21.0m		24.0m		27.0m		30.0m		31.5m		m		
		Icon	Icon	Icon	Icon	Icon	Icon	Icon	Icon	Icon	Icon	Icon	Icon	Icon	Icon	Icon	Icon	Icon	Icon	Icon	Icon	Icon	Icon	Icon
33.0	4 pt. outriggers down							10.8*	10.8*													10.4*	10.4*	15.3
30.0	4 pt. outriggers down									11.1*	11.1*											9.1*	9.1*	19.5
27.0	4 pt. outriggers down									12.2*	12.2*	10.7*	10.7*									8.4*	8.4*	22.5
24.0	4 pt. outriggers down									12.1*	12.1*	10.6*	10.6*	9.4*	9.4*							8.0*	8.0*	24.8
21.0	4 pt. outriggers down									12.1*	12.1*	10.6*	10.6*	9.4*	9.4*							7.8*	7.8*	26.5
18.0	4 pt. outriggers down									12.3*	12.3*	10.7*	10.7*	9.4*	9.4*	8.5*	8.5*					7.7*	7.7*	27.8
15.0	4 pt. outriggers down									12.5*	12.5*	10.8*	10.8*	9.5*	9.5*	8.5*	8.5*					7.8*	7.8*	28.8
12.0	4 pt. outriggers down					18.9*	18.9*	15.2*	15.2*	12.8*	12.8*	11.0*	11.0*	9.6*	9.6*	8.6*	8.6*					7.8*	7.8*	29.4
9.0	4 pt. outriggers down	40.4*	40.4*	26.6*	26.6*	19.8*	19.8*	15.8*	15.8*	13.1*	13.1*	11.2*	11.2*	9.7*	9.7*	8.6*	8.6*					7.7*	7.7*	29.7
6.0	4 pt. outriggers down	17.0*	17.0*	28.3*	28.3*	20.7*	20.7*	16.3*	16.3*	13.4*	13.4*	11.4*	11.4*	9.9*	9.9*	8.6*	8.6*					7.6*	7.6*	29.7
3.0	4 pt. outriggers down	10.0*	10.0*	26.1*	26.1*	21.4*	21.4*	16.7*	16.7*	13.7*	13.7*	11.5*	11.5*	9.9*	9.9*	8.5*	8.5*					7.4*	7.4*	29.4
0	4 pt. outriggers down	10.1*	10.1*	19.0*	19.0*	21.6*	21.6*	16.9*	16.9*	13.8*	13.8*	11.5*	11.5*	9.8*	9.8*	8.2*	8.2*					7.2*	7.2*	28.8
-3.0	4 pt. outriggers down	11.3*	11.3*	17.9*	17.9*	21.1*	21.1*	16.6*	16.6*	13.5*	13.5*	11.2*	11.2*	9.3*	9.3*	7.5*	7.5*					6.9*	6.9*	27.8
-6.0	4 pt. outriggers down			18.3*	18.3*	19.4*	19.4*	15.5*	15.5*	12.6*	12.6*	10.3*	10.3*	8.2*	8.2*							6.4*	6.4*	26.3
-9.0	4 pt. outriggers down							13.1*	13.1*	10.7*	10.7*											8.7*	8.7*	20.6

Height Can be slewed through 360° In longitudinal position of undercarriage Max. reach \* Limited by hydr. capacity

The lift capacities on the stick end without attachment are stated in metric tons (t) and are valid on a firm, level supporting surface with blocked oscillating axle. These capacities can be slewed through 360° with the undercarriage in the transverse position. Capacities in the longitudinal position of the undercarriage (±15°) are specified over the rigid axle with the stabilizers down. Indicated loads based on the ISO 10567 standard and do not exceed 75% of tipping or 87% of hydraulic capacity. The lift capacity values indicated are attained at the corresponding operating temperature. This operating temperature is ensured by continuous movement of the boom. Weights of fitted attachments (grabs, load hooks, etc.) and load accommodation attachment are to be deducted from the lift capacity values. The lift capacity of the unit is limited by its stability, the lifting capability of the hydraulic elements, or the maximum permissible lifting capacity of the load hook. In accordance with the harmonised European Standard EN 474-5, hydraulic excavators used for lifting operations must be equipped with pipe fracture safety valves, an overload warning device, a load hook and a lift capacity chart.

# LH 150 M Gantry – Equipment AG31

## Port – Kinematic 2D

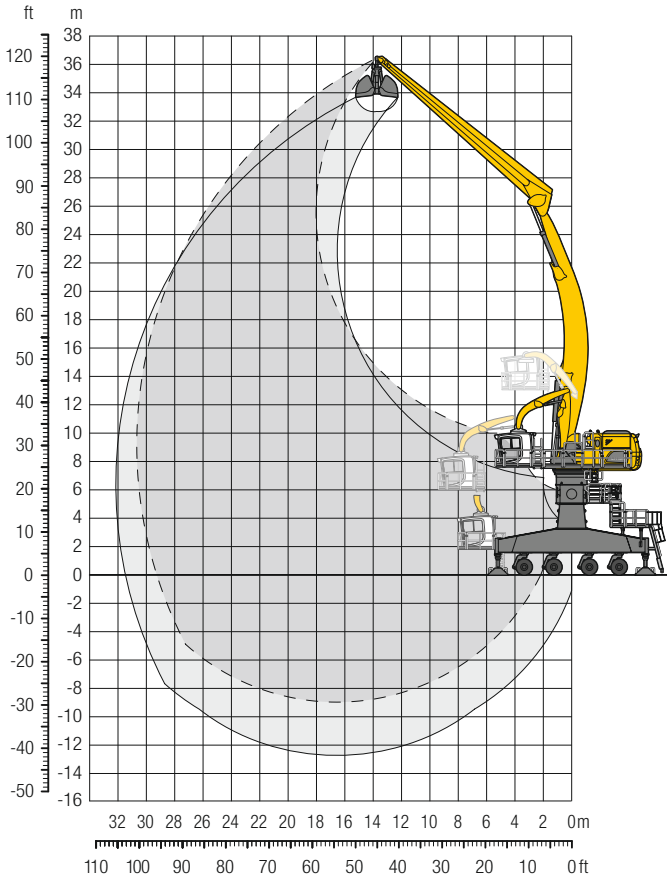

### Dimensions

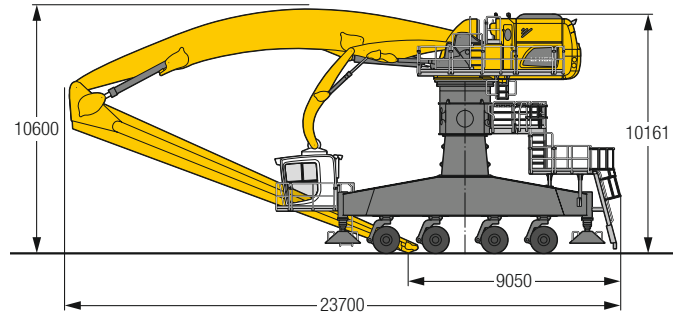

### Operating weight

The operating weight includes the basic machine with 4 point outriggers, hydr. cab elevation, 32 solid tyres, angled boom 16.50 m, straight stick 16.00 m and grab for loose material GMZ 120 / 8.00 m<sup>3</sup>.

Weight	176,000 kg
--------	------------

m	Undercarriage	6.0m		9.0m		12.0m		15.0m		18.0m		21.0m		24.0m		27.0m		30.0m		31.5m		m			
		Can be slewed through 360°	In longitudinal position of undercarriage	Can be slewed through 360°	In longitudinal position of undercarriage	Can be slewed through 360°	In longitudinal position of undercarriage	Can be slewed through 360°	In longitudinal position of undercarriage	Can be slewed through 360°	In longitudinal position of undercarriage	Can be slewed through 360°	In longitudinal position of undercarriage	Can be slewed through 360°	In longitudinal position of undercarriage	Can be slewed through 360°	In longitudinal position of undercarriage	Can be slewed through 360°	In longitudinal position of undercarriage	Can be slewed through 360°	In longitudinal position of undercarriage	Can be slewed through 360°	In longitudinal position of undercarriage		
36.0	4 pt. outriggers down																					10.1*	10.1*	14.7	
33.0	4 pt. outriggers down									10.2*	10.2*												8.7*	8.7*	19.2
30.0	4 pt. outriggers down									12.0*	12.0*	9.9*	9.9*										7.9*	7.9*	22.5
27.0	4 pt. outriggers down									11.9*	11.9*	10.4*	10.4*	9.0*	9.0*								7.5*	7.5*	24.9
24.0	4 pt. outriggers down									11.9*	11.9*	10.4*	10.4*	9.2*	9.2*								7.2*	7.2*	26.8
21.0	4 pt. outriggers down									12.0*	12.0*	10.4*	10.4*	9.2*	9.2*	8.3*	8.3*						7.1*	7.1*	28.3
18.0	4 pt. outriggers down									12.1*	12.1*	10.5*	10.5*	9.3*	9.3*	8.3*	8.3*						7.1*	7.1*	29.4
15.0	4 pt. outriggers down							14.7*	14.7*	12.4*	12.4*	10.7*	10.7*	9.4*	9.4*	8.4*	8.4*	7.5*	7.5*				7.2*	7.2*	30.1
12.0	4 pt. outriggers down					18.9*	18.9*	15.2*	15.2*	12.7*	12.7*	10.9*	10.9*	9.5*	9.5*	8.5*	8.5*	7.5*	7.5*				7.4*	7.4*	30.5
9.0	4 pt. outriggers down	41.2*	41.2*	26.9*	26.9*	19.9*	19.9*	15.8*	15.8*	13.1*	13.1*	11.1*	11.1*	9.7*	9.7*	8.5*	8.5*	7.5*	7.5*				7.3*	7.3*	30.7
6.0	4 pt. outriggers down	14.9*	14.9*	28.4*	28.4*	20.8*	20.8*	16.3*	16.3*	13.4*	13.4*	11.3*	11.3*	9.8*	9.8*	8.5*	8.5*	7.4*	7.4*				7.2*	7.2*	30.5
3.0	4 pt. outriggers down	10.6*	10.6*	24.3*	24.3*	21.4*	21.4*	16.7*	16.7*	13.6*	13.6*	11.4*	11.4*	9.8*	9.8*	8.4*	8.4*	7.1*	7.1*				7.0*	7.0*	30.0
0	4 pt. outriggers down	10.8*	10.8*	19.0*	19.0*	21.4*	21.4*	16.8*	16.8*	13.6*	13.6*	11.4*	11.4*	9.6*	9.6*	8.1*	8.1*						6.8*	6.8*	29.3
-3.0	4 pt. outriggers down	11.8*	11.8*	18.1*	18.1*	20.7*	20.7*	16.3*	16.3*	13.3*	13.3*	11.0*	11.0*	9.1*	9.1*	7.3*	7.3*						6.5*	6.5*	28.1
-6.0	4 pt. outriggers down			18.5*	18.5*	18.7*	18.7*	15.0*	15.0*	12.2*	12.2*	9.9*	9.9*	7.9*	7.9*								6.5*	6.5*	25.9

Height Can be slewed through 360° In longitudinal position of undercarriage Max. reach \* Limited by hydr. capacity

The lift capacities on the stick end without attachment are stated in metric tons (t) and are valid on a firm, level supporting surface with blocked oscillating axle. These capacities can be slewed through 360° with the undercarriage in the transverse position. Capacities in the longitudinal position of the undercarriage (±15°) are specified over the rigid axle with the stabilizers down. Indicated loads based on the ISO 10567 standard and do not exceed 75% of tipping or 87% of hydraulic capacity. The lift capacity values indicated are attained at the corresponding operating temperature. This operating temperature is ensured by continuous movement of the boom. Weights of fitted attachments (grabs, load hooks, etc.) and load accommodation attachment are to be deducted from the lift capacity values. The lift capacity of the unit is limited by its stability, the lifting capability of the hydraulic elements, or the maximum permissible lifting capacity of the load hook. In accordance with the harmonised European Standard EN 474-5, hydraulic excavators used for lifting operations must be equipped with pipe fracture safety valves, an overload warning device, a load hook and a lift capacity chart.



# LH 150 M – Equipment GG17

## Port – Kinematic 2A

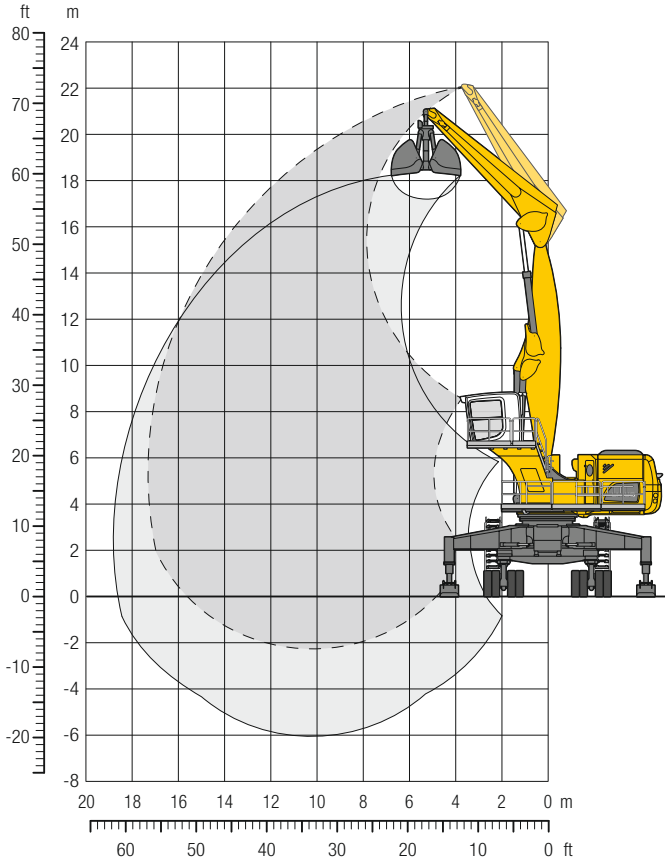

### Dimensions

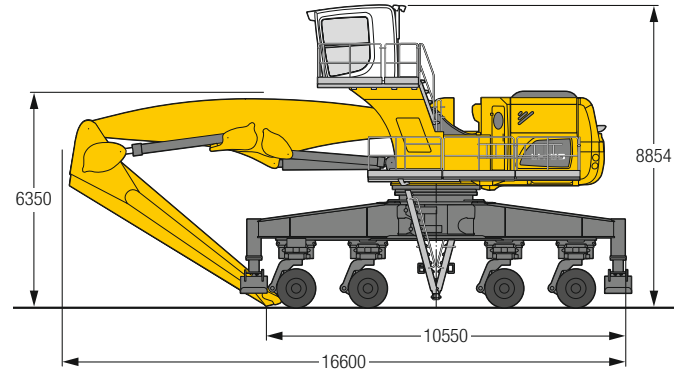

### Operating weight

The operating weight includes the basic machine with 4 point outriggers, rigid cab elevation, 32 solid tyres, straight boom 10.00 m, straight stick 7.50 m and grab for loose material GMZ 120 / 8,00 m<sup>3</sup>.

Weight 147,700 kg

m	Undercarriage	6.0m		9.0m		12.0m		15.0m		18.0m		21.0m		24.0m		27.0m		30.0m		31.5m		m		
		35.9*	35.9*	32.8*	32.8*	27.1*	27.1*	23.7*	23.7*	27.5*	27.5*	23.9*	23.9*	24.1*	24.1*	17.4*	17.4*	17.9*	17.9*	17.1*	17.1*	18.1*	18.1*	
21.0	4 pt. outriggers down																					28.1*	28.1*	7.6
18.0	4 pt. outriggers down																					21.0*	21.0*	11.9
15.0	4 pt. outriggers down																					18.6*	18.6*	14.5
12.0	4 pt. outriggers down																					17.6*	17.6*	16.0
9.0	4 pt. outriggers down	49.4*	49.4*	36.2*	36.2*	27.5*	27.5*	23.7*	23.7*	23.9*	23.9*	24.1*	24.1*	17.4*	17.4*	17.9*	17.9*	17.1*	17.1*	18.1*	18.1*	17.4*	17.4*	16.9
6.0	4 pt. outriggers down	60.2*	60.2*	39.7*	39.7*	30.1*	30.1*	24.1*	24.1*	23.9*	23.9*	24.1*	24.1*	17.9*	17.9*	17.1*	17.1*	18.1*	18.1*	17.1*	17.1*	17.9*	17.9*	17.3
3.0	4 pt. outriggers down	28.1*	28.1*	41.5*	41.5*	30.5*	30.5*	23.2*	23.2*	23.9*	23.9*	24.1*	24.1*	17.1*	17.1*	18.1*	18.1*	17.1*	17.1*	18.1*	18.1*	17.1*	17.1*	17.1
0	4 pt. outriggers down	28.9*	28.9*	38.3*	38.3*	27.9*	27.9*	19.2*	19.2*	23.9*	23.9*	24.1*	24.1*	18.1*	18.1*	17.1*	17.1*	18.1*	18.1*	17.1*	17.1*	18.1*	18.1*	15.3
-3.0	4 pt. outriggers down																							

Height 
 Can be slewed through 360° 
 In longitudinal position of undercarriage 
 Max. reach 
 \* Limited by hydr. capacity

The lift capacities on the stick end without attachment are stated in metric tons (t) and are valid on a firm, level supporting surface with blocked oscillating axle. These capacities can be slewed through 360° with the undercarriage in the transverse position. Capacities in the longitudinal position of the undercarriage (±15°) are specified over the rigid axle with the stabilizers down. Indicated loads based on the ISO 10567 standard and do not exceed 75% of tipping or 87% of hydraulic capacity. The lift capacity values indicated are attained at the corresponding operating temperature. This operating temperature is ensured by continuous movement of the boom. Weights of fitted attachments (grabs, load hooks, etc.) and load accommodation attachment are to be deducted from the lift capacity values. The lift capacity of the unit is limited by its stability, the lifting capability of the hydraulic elements, or the maximum permissible lifting capacity of the load hook. In accordance with the harmonised European Standard EN 474-5, hydraulic excavators used for lifting operations must be equipped with pipe fracture safety valves, an overload warning device, a load hook and a lift capacity chart.

# LH 150 C – Equipment GG19

## Port – Kinematic 2A

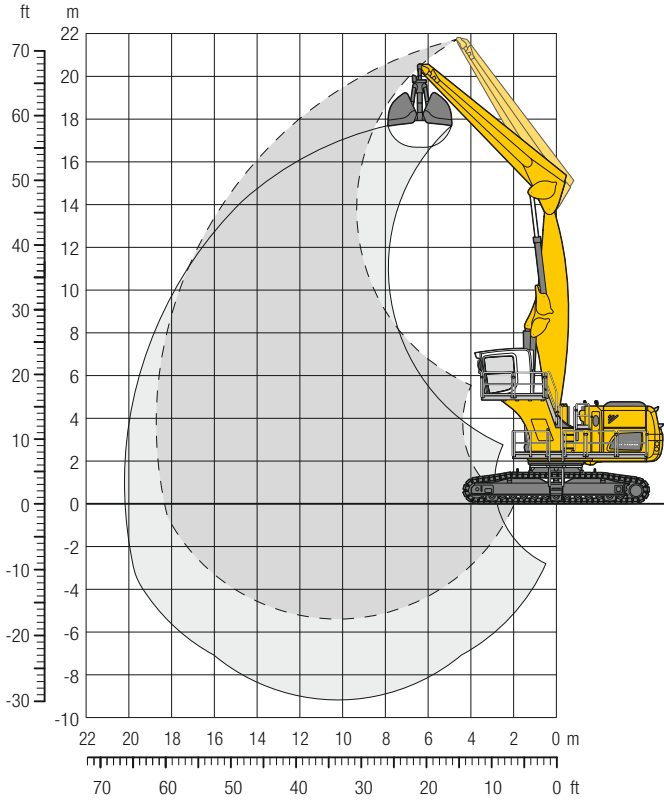

### Dimensions

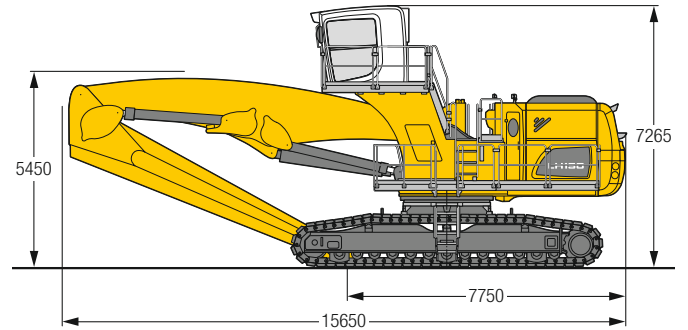

### Operating weight and ground pressure

The operating weight includes the basic machine with rigid cab elevation, straight boom 10.00 m, straight stick 9.00 m and grab for loose material GMZ 120 / 8.00 m<sup>3</sup>.

Weight	138,100 kg
Pad width	750 mm
Ground pressure	on request

m	Undercarriage	6.0m		9.0m		12.0m		15.0m		18.0m		21.0m		24.0m		27.0m		30.0m		31.5m		Max. reach		m
		Can be slewed through 360°	In longitudinal position of undercarriage	Can be slewed through 360°	In longitudinal position of undercarriage	Can be slewed through 360°	In longitudinal position of undercarriage	Can be slewed through 360°	In longitudinal position of undercarriage	Can be slewed through 360°	In longitudinal position of undercarriage	Can be slewed through 360°	In longitudinal position of undercarriage	Can be slewed through 360°	In longitudinal position of undercarriage	Can be slewed through 360°	In longitudinal position of undercarriage	Can be slewed through 360°	In longitudinal position of undercarriage	Can be slewed through 360°	In longitudinal position of undercarriage	Can be slewed through 360°	In longitudinal position of undercarriage	
21.0	SW	29.7*	29.7*																			26.3*	26.3*	6.7
18.0	SW			28.6*	28.6*																	18.4*	18.4*	11.9
15.0	SW					25.9*	25.9*															16.0*	16.0*	14.8
12.0	SW					25.7*	25.7*	22.9*	22.9*													15.0*	15.0*	16.7
9.0	SW					26.7*	26.7*	23.2*	23.2*													14.6*	14.6*	17.9
6.0	SW	38.6*	38.6*	35.5*	35.5*	28.4*	28.4*	23.8*	23.8*	19.3*	19.3*											14.7*	14.7*	18.5
3.0	SW	59.6*	59.6*	39.6*	39.6*	30.2*	30.2*	24.4*	24.4*	19.5*	19.5*											15.2*	15.2*	18.6
0	SW	35.5*	35.5*	41.8*	41.8*	30.9*	30.9*	24.0*	24.0*	17.0*	17.0*											16.0*	16.0*	18.3
-3.0	SW	31.8*	31.8*	39.4*	39.4*	28.8*	28.8*	20.9*	20.9*													17.2*	17.2*	16.3

Height Can be slewed through 360° In longitudinal position of undercarriage Max. reach \* Limited by hydr. capacity

The lift capacities on the stick end without attachment are stated in metric tons (t) and can be slewed through 360° on a firm, level supporting surface. Capacities are valid for 750 mm wide flat pads. Indicated loads based on the ISO 10567 standard and do not exceed 75% of tipping or 87% of hydraulic capacity. The lift capacity values indicated are attained at the corresponding operating temperature. This operating temperature is ensured by continuous movement of the boom. Weights of fitted attachments (grabs, load hooks, etc.) and load accommodation attachment are to be deducted from the lift capacity values. The lift capacity of the unit is limited by its stability, the lifting capability of the hydraulic elements, or the maximum permissible lifting capacity of the load hook.

In accordance with the harmonised European Standard EN 474-5, hydraulic excavators used for lifting operations must be equipped with pipe fracture safety valves, an overload warning device, a load hook and a lift capacity chart.

# LH 150 M HR – Equipment GG25

## Port – Kinematic 2A

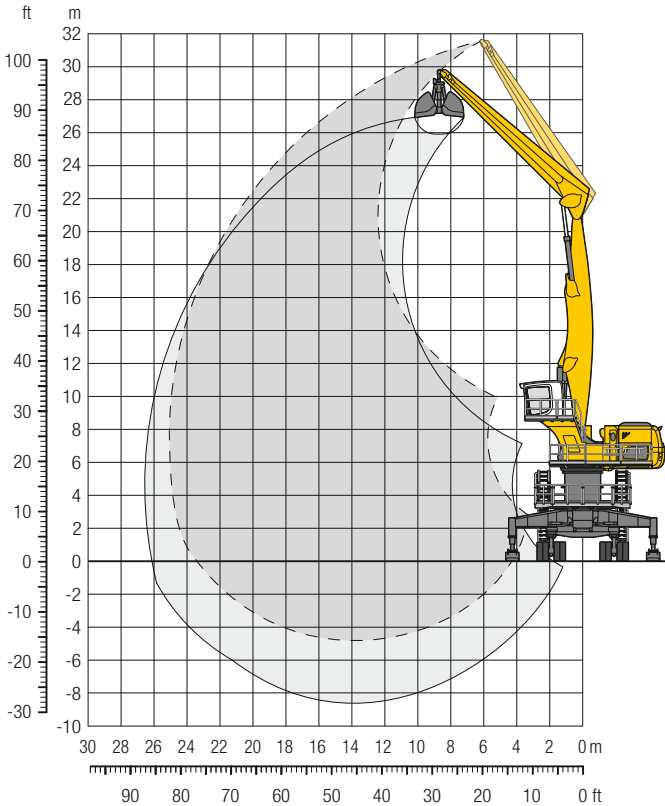

### Dimensions

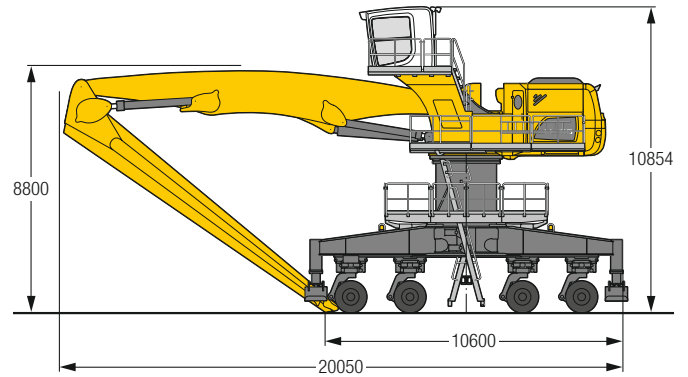

### Operating weight

The operating weight includes the basic machine with 4 point outriggers, turret 2,000 mm, rigid cab elevation, 32 solid tyres, straight boom 13.50 m, straight stick 12.00 m and grab for loose material GMZ 120/8.00 m<sup>3</sup>.

Weight 161.000 kg

m	Undercarriage	6.0m		9.0m		12.0m		15.0m		18.0m		21.0m		24.0m		27.0m		30.0m		31.5m		m	
		4 pt. outriggers down	4 pt. outriggers down	4 pt. outriggers down	4 pt. outriggers down	4 pt. outriggers down	4 pt. outriggers down	4 pt. outriggers down	4 pt. outriggers down	4 pt. outriggers down	4 pt. outriggers down	4 pt. outriggers down	4 pt. outriggers down	4 pt. outriggers down	4 pt. outriggers down	4 pt. outriggers down	4 pt. outriggers down	4 pt. outriggers down	4 pt. outriggers down	4 pt. outriggers down	4 pt. outriggers down	4 pt. outriggers down	4 pt. outriggers down
30.0	4 pt. outriggers down			21.1*	21.1*																17.2*	17.2*	10.7
27.0	4 pt. outriggers down					20.5*	20.5*	15.1*	15.1*												13.5*	13.5*	15.5
24.0	4 pt. outriggers down							18.7*	18.7*	14.3*	14.3*										11.9*	11.9*	18.7
21.0	4 pt. outriggers down							18.5*	18.5*	16.2*	16.2*										11.0*	11.0*	21.0
18.0	4 pt. outriggers down					21.9*	21.9*	18.6*	18.6*	16.2*	16.2*	14.4*	14.4*								10.6*	10.6*	22.6
15.0	4 pt. outriggers down					22.6*	22.6*	19.0*	19.0*	16.4*	16.4*	14.4*	14.4*								10.4*	10.4*	23.8
12.0	4 pt. outriggers down			26.7*	26.7*	23.7*	23.7*	19.6*	19.6*	16.7*	16.7*	14.5*	14.5*	12.5*	12.5*						10.4*	10.4*	24.5
9.0	4 pt. outriggers down	45.0*	45.0*	33.1*	33.1*	25.1*	25.1*	20.3*	20.3*	17.1*	17.1*	14.6*	14.6*	12.3*	12.3*						10.6*	10.6*	24.9
6.0	4 pt. outriggers down	18.7*	18.7*	35.6*	35.6*	26.3*	26.3*	20.9*	20.9*	17.2*	17.2*	14.5*	14.5*	11.7*	11.7*						10.5*	10.5*	24.9
3.0	4 pt. outriggers down	11.9*	11.9*	36.2*	36.2*	26.7*	26.7*	20.9*	20.9*	17.0*	17.0*	13.9*	13.9*	10.3*	10.3*						9.3*	9.3*	24.5
0	4 pt. outriggers down	13.6*	13.6*	30.6*	30.6*	25.5*	25.5*	20.0*	20.0*	15.9*	15.9*	12.3*	12.3*								9.1*	9.1*	23.1
-3.0	4 pt. outriggers down			27.7*	27.7*	21.9*	21.9*	17.2*	17.2*	13.2*	13.2*										10.9*	10.9*	19.6
-6.0	4 pt. outriggers down																						

Height 
 Can be slewed through 360° 
 In longitudinal position of undercarriage 
 Max. reach 
 \* Limited by hydr. capacity

The lift capacities on the stick end without attachment are stated in metric tons (t) and are valid on a firm, level supporting surface with blocked oscillating axle. These capacities can be slewed through 360° with the undercarriage in the transverse position. Capacities in the longitudinal position of the undercarriage (±15°) are specified over the rigid axle with the stabilizers down. Indicated loads based on the ISO 10567 standard and do not exceed 75% of tipping or 87% of hydraulic capacity. The lift capacity values indicated are attained at the corresponding operating temperature. This operating temperature is ensured by continuous movement of the boom. Weights of fitted attachments (grabs, load hooks, etc.) and load accommodation attachment are to be deducted from the lift capacity values. The lift capacity of the unit is limited by its stability, the lifting capability of the hydraulic elements, or the maximum permissible lifting capacity of the load hook. In accordance with the harmonised European Standard EN 474-5, hydraulic excavators used for lifting operations must be equipped with pipe fracture safety valves, an overload warning device, a load hook and a lift capacity chart.

# LH 150 C HR – Equipment GG28

## Port – Kinematic 2A

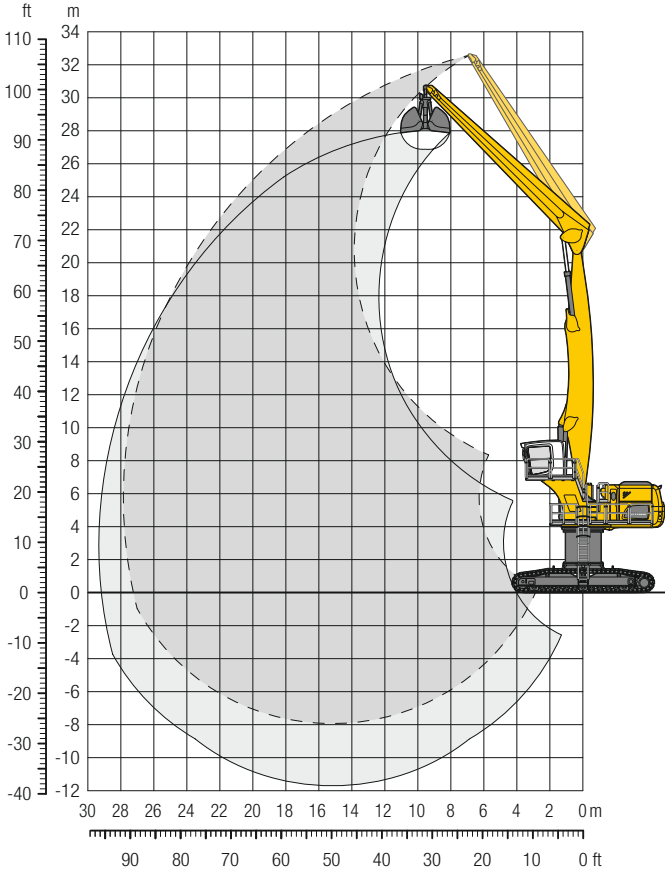

### Dimensions

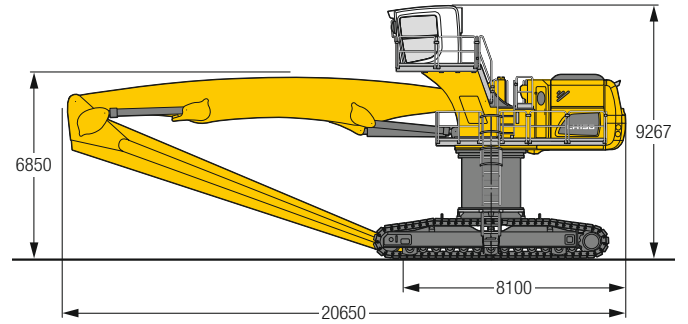

### Operating weight and ground pressure

The operating weight includes the basic machine with turret 2,000 mm, rigid cab elevation, straight boom 15.00 m, straight stick 13.50 m and grab for loose material GMZ 120 / 8.00 m<sup>3</sup>.

Weight	149,100 kg
Pad width	750 mm
Ground pressure	on request

m	Undercarriage	6.0m		9.0m		12.0m		15.0m		18.0m		21.0m		24.0m		27.0m		30.0m		31.5m		Max. reach		
		SW	SW	SW	SW	SW	SW	SW	SW	SW	SW	SW	SW	SW	SW	SW	SW	SW	SW	SW	SW	SW	m	
30.0	SW					16.8*	16.8*															13.9*	13.9*	13.5
27.0	SW							16.6*	16.6*													11.5*	11.5*	17.9
24.0	SW							17.6*	17.6*	15.2*	15.2*											10.3*	10.3*	21.0
21.0	SW							17.4*	17.4*	15.0*	15.0*	13.3*	13.3*									9.6*	9.6*	23.3
18.0	SW							17.5*	17.5*	15.0*	15.0*	13.2*	13.2*	11.7*	11.7*							9.2*	9.2*	25.0
15.0	SW							17.8*	17.8*	15.2*	15.2*	13.2*	13.2*	11.7*	11.7*							9.0*	9.0*	26.3
12.0	SW					22.2*	22.2*	18.2*	18.2*	15.4*	15.4*	13.4*	13.4*	11.7*	11.7*	9.5*	9.5*					8.9*	8.9*	27.1
9.0	SW			26.1*	26.1*	23.2*	23.2*	18.8*	18.8*	15.7*	15.7*	13.5*	13.5*	11.7*	11.7*	9.9*	9.9*					9.0*	9.0*	27.7
6.0	SW			32.6*	32.6*	24.3*	24.3*	19.3*	19.3*	16.0*	16.0*	13.6*	13.6*	11.6*	11.6*	9.6*	9.6*					8.8*	8.8*	27.8
3.0	SW	9.3*	9.3*	34.0*	34.0*	24.9*	24.9*	19.6*	19.6*	16.1*	16.1*	13.5*	13.5*	11.3*	11.3*	8.9*	8.9*					8.0*	8.0*	27.7
0	SW	8.8*	8.8*	23.8*	23.8*	24.8*	24.8*	19.5*	19.5*	15.8*	15.8*	13.0*	13.0*	10.6*	10.6*	7.4*	7.4*					7.0*	7.0*	27.2
-3.0	SW	10.8*	10.8*	20.9*	20.9*	23.3*	23.3*	18.4*	18.4*	14.8*	14.8*	11.9*	11.9*	9.1*	9.1*							7.0*	7.0*	25.6
-6.0	SW			21.8*	21.8*	19.7*	19.7*	15.8*	15.8*	12.6*	12.6*	9.6*	9.6*									8.4*	8.4*	22.2

Height Can be slewed through 360° In longitudinal position of undercarriage Max. reach \* Limited by hydr. capacity

The lift capacities on the stick end without attachment are stated in metric tons (t) and can be slewed through 360° on a firm, level supporting surface. Capacities are valid for 750 mm wide flat pads. Indicated loads based on the ISO 10567 standard and do not exceed 75% of tipping or 87% of hydraulic capacity. The lift capacity values indicated are attained at the corresponding operating temperature. This operating temperature is ensured by continuous movement of the boom. Weights of fitted attachments (grabs, load hooks, etc.) and load accommodation attachment are to be deducted from the lift capacity values. The lift capacity of the unit is limited by its stability, the lifting capability of the hydraulic elements, or the maximum permissible lifting capacity of the load hook. In accordance with the harmonised European Standard EN 474-5, hydraulic excavators used for lifting operations must be equipped with pipe fracture safety valves, an overload warning device, a load hook and a lift capacity chart.



# LH 150 C Gantry – Equipment GG31

## Port – Kinematic 2A

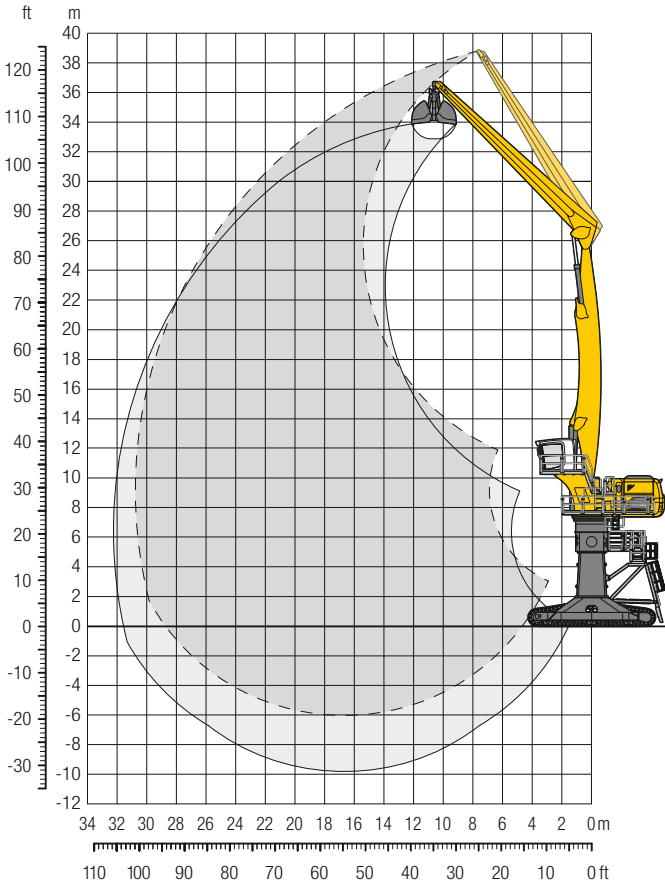

### Dimensions

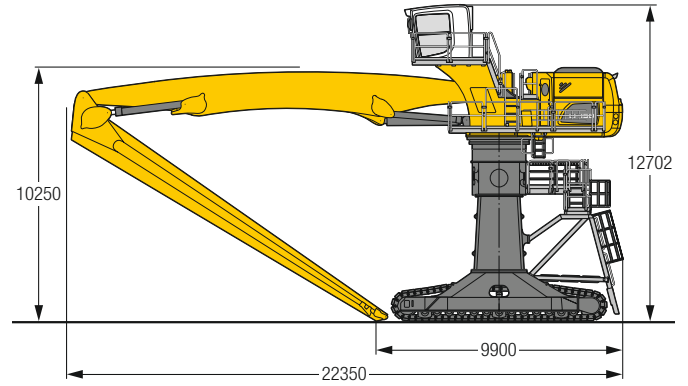

### Operating weight and ground pressure

The operating weight includes the basic machine with rigid cab elevation, straight boom 16.50 m, straight stick 15.00 m and grab for loose material GMZ 120 / 8.00 m<sup>3</sup>.

Weight	161,200 kg
Pad width	750 mm
Ground pressure	on request

m	Undercarriage	6.0m		9.0m		12.0m		15.0m		18.0m		21.0m		24.0m		27.0m		30.0m		31.5m		Max. reach		m
		Can be slewed through 360°	Can be slewed through 360°	Can be slewed through 360°	Can be slewed through 360°	Can be slewed through 360°	Can be slewed through 360°	Can be slewed through 360°	Can be slewed through 360°	Can be slewed through 360°	Can be slewed through 360°	Can be slewed through 360°	Can be slewed through 360°	Can be slewed through 360°	Can be slewed through 360°	Can be slewed through 360°	Can be slewed through 360°	Can be slewed through 360°	Can be slewed through 360°	Can be slewed through 360°	Can be slewed through 360°	Can be slewed through 360°		
39.0	Gantry																							
36.0	Gantry					16.2*	16.2*															12.2*	12.2*	14.8
33.0	Gantry							15.8*	15.8*	12.6*	12.6*											10.2*	10.2*	19.3
30.0	Gantry							17.0*	17.0*	14.3*	14.3*	12.0*	12.0*									9.1*	9.1*	22.6
27.0	Gantry									14.2*	14.2*	12.2*	12.2*	10.7*	10.7*							8.5*	8.5*	25.0
24.0	Gantry									14.1*	14.1*	12.2*	12.2*	10.7*	10.7*							8.1*	8.1*	26.9
21.0	Gantry									16.9*	16.9*	14.2*	14.2*	10.6*	10.6*	9.3*	9.3*					7.9*	7.9*	28.4
18.0	Gantry									17.1*	17.1*	14.3*	14.3*	12.2*	12.2*	10.6*	10.6*	9.3*	9.3*			7.7*	7.7*	29.5
15.0	Gantry																					7.7*	7.7*	30.2
12.0	Gantry																					7.2*	7.2*	30.6
9.0	Gantry																					6.7*	6.7*	30.8
6.0	Gantry																					6.0*	6.0*	30.6
3.0	Gantry																					5.2*	5.2*	30.1
0	Gantry																					5.0*	5.0*	28.7
-3.0	Gantry																					5.7*	5.7*	25.7
-6.0	Gantry																					9.2*	9.2*	17.5

Height Can be slewed through 360° In longitudinal position of undercarriage Max. reach \* Limited by hydr. capacity

The lift capacities on the stick end without attachment are stated in metric tons (t) and can be slewed through 360° on a firm, level supporting surface. Capacities are valid for 750 mm wide flat pads. Indicated loads based on the ISO 10567 standard and do not exceed 75% of tipping or 87% of hydraulic capacity. The lift capacity values indicated are attained at the corresponding operating temperature. This operating temperature is ensured by continuous movement of the boom. Weights of fitted attachments (grabs, load hooks, etc.) and load accommodation attachment are to be deducted from the lift capacity values. The lift capacity of the unit is limited by its stability, the lifting capability of the hydraulic elements, or the maximum permissible lifting capacity of the load hook. In accordance with the harmonised European Standard EN 474-5, hydraulic excavators used for lifting operations must be equipped with pipe fracture safety valves, an overload warning device, a load hook and a lift capacity chart.

# LH 150 M Gantry – Equipment GG32

## Port – Kinematic 2A

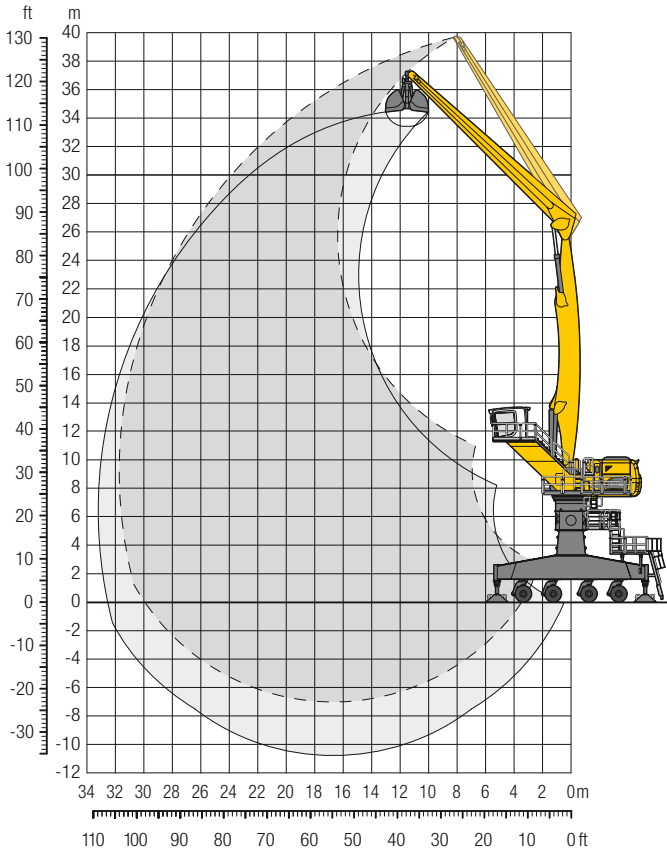

### Dimensions

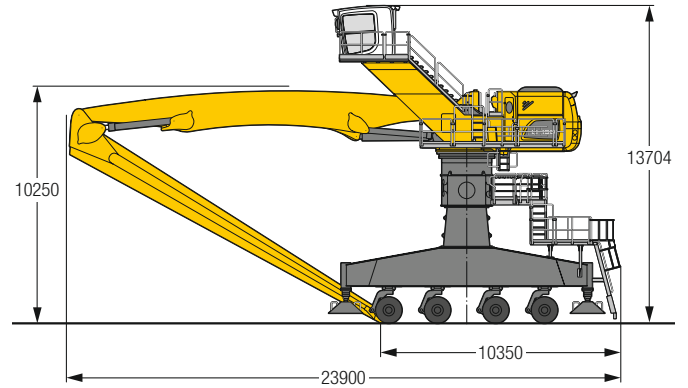

### Operating weight

The operating weight includes the basic machine with 4 point outriggers, rigid cab elevation, 32 solid tyres, straight boom 16.50 m, straight stick 16.00 m and grab for loose material GMZ 120 / 8.00 m<sup>3</sup>.

Weight 171,300 kg

m	Undercarriage	6.0m		9.0m		12.0m		15.0m		18.0m		21.0m		24.0m		27.0m		30.0m		31.5m		m		
		Outrigger	Outrigger	Outrigger	Outrigger	Outrigger	Outrigger	Outrigger	Outrigger	Outrigger	Outrigger	Outrigger	Outrigger	Outrigger	Outrigger	Outrigger	Outrigger	Outrigger	Outrigger	Outrigger	Outrigger	Outrigger	Outrigger	Outrigger
39.0	4 pt. outriggers down																					14.7*	14.7*	10.4
36.0	4 pt. outriggers down							13.3*	13.3*													10.7*	10.7*	16.7
33.0	4 pt. outriggers down							15.5*	15.5*	13.2*	13.2*											9.2*	9.2*	20.8
30.0	4 pt. outriggers down									14.1*	14.1*	12.2*	12.2*									8.3*	8.3*	23.9
27.0	4 pt. outriggers down									14.0*	14.0*	12.1*	12.1*	10.6*	10.6*							7.8*	7.8*	26.2
24.0	4 pt. outriggers down									14.0*	14.0*	12.0*	12.0*	10.5*	10.5*	9.3*	9.3*					7.4*	7.4*	28.0
21.0	4 pt. outriggers down									14.0*	14.0*	12.1*	12.1*	10.5*	10.5*	9.3*	9.3*					7.2*	7.2*	29.4
18.0	4 pt. outriggers down							16.8*	16.8*	14.1*	14.1*	12.1*	12.1*	10.5*	10.5*	9.2*	9.2*	8.0*	8.0*			7.1*	7.1*	30.5
15.0	4 pt. outriggers down							17.2*	17.2*	14.3*	14.3*	12.2*	12.2*	10.6*	10.6*	9.2*	9.2*	7.9*	7.9*			7.1*	7.1*	31.2
12.0	4 pt. outriggers down			18.0*	18.0*	22.0*	22.0*	17.5*	17.5*	14.5*	14.5*	12.3*	12.3*	10.6*	10.6*	9.2*	9.2*	7.8*	7.8*	6.9*	6.9*	6.9*	6.9*	31.6
9.0	4 pt. outriggers down			30.7*	30.7*	22.6*	22.6*	17.8*	17.8*	14.6*	14.6*	12.3*	12.3*	10.5*	10.5*	9.0*	9.0*	7.6*	7.6*	6.6*	6.6*	6.4*	6.4*	31.7
6.0	4 pt. outriggers down			31.4*	31.4*	23.0*	23.0*	18.0*	18.0*	14.7*	14.7*	12.3*	12.3*	10.4*	10.4*	8.8*	8.8*	7.1*	7.1*	5.8*	5.8*	5.8*	5.8*	31.6
3.0	4 pt. outriggers down	7.0*	7.0*	18.9*	18.9*	22.7*	22.7*	17.8*	17.8*	14.4*	14.4*	12.0*	12.0*	10.0*	10.0*	8.3*	8.3*	6.2*	6.2*			5.0*	5.0*	31.1
0	4 pt. outriggers down	8.3*	8.3*	16.0*	16.0*	21.6*	21.6*	17.0*	17.0*	13.8*	13.8*	11.3*	11.3*	9.3*	9.3*	7.3*	7.3*					4.6*	4.6*	29.9
-3.0	4 pt. outriggers down			16.3*	16.3*	19.1*	19.1*	15.3*	15.3*	12.4*	12.4*	10.0*	10.0*	7.9*	7.9*	5.5*	5.5*					5.2*	5.2*	27.3
-6.0	4 pt. outriggers down					14.7*	14.7*	12.2*	12.2*	9.9*	9.9*	7.7*	7.7*									6.7*	6.7*	22.3

Height 
 Can be slewed through 360° 
 In longitudinal position of undercarriage 
 Max. reach 
 \* Limited by hydr. capacity

The lift capacities on the stick end without attachment are stated in metric tons (t) and are valid on a firm, level supporting surface with blocked oscillating axle. These capacities can be slewed through 360° with the undercarriage in the transverse position. Capacities in the longitudinal position of the undercarriage (±15°) are specified over the rigid axle with the stabilizers down. Indicated loads based on the ISO 10567 standard and do not exceed 75% of tipping or 87% of hydraulic capacity. The lift capacity values indicated are attained at the corresponding operating temperature. This operating temperature is ensured by continuous movement of the boom. Weights of fitted attachments (grabs, load hooks, etc.) and load accommodation attachment are to be deducted from the lift capacity values. The lift capacity of the unit is limited by its stability, the lifting capability of the hydraulic elements, or the maximum permissible lifting capacity of the load hook. In accordance with the harmonised European Standard EN 474-5, hydraulic excavators used for lifting operations must be equipped with pipe fracture safety valves, an overload warning device, a load hook and a lift capacity chart.

# Attachments

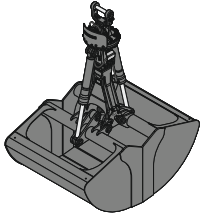

## Grab for loose material

Shells for loose material with cutting edge (without teeth)

Grab model GMZ 120								
Width of shells	mm	1,600	1,800	2,000	2,200	2,400	2,800	3,200
Capacity	m <sup>3</sup>	4.00	4.50	5.00	5.50	6.00	7.00	8.00
Weight	kg	3,005	3,140	3,280	3,630	3,775	4,040	4,330

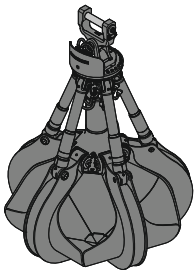

## Multi-tine grab

closed, heart-shaped

Grab model GMM 120-5 (5 tines)					
Capacity	m <sup>3</sup>	1.70	2.00	2.50	3.00
Weight	kg	2,970	3,110	3,265	3,670



## Wood grab

Grab model GMH 120 round-shaped (complete overlapping, vertical cylinders)			
Size	m <sup>2</sup>	2.80	3.20
Cutting width	mm	870	870
Height of grab, closed	mm	3,574	3,673
Weight	kg	2,770	2,800
Grab model GMH 120 round-shaped (complete overlapping, straight design, vertical cylinders, two over one grab)			
Size	m <sup>2</sup>	1.40	
Cutting width	mm	870	
Height of grab, closed	mm	2,947	
Weight	kg	2,590	

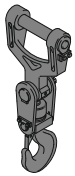

## Load hook

Max. load	t	25
Weight	kg	255

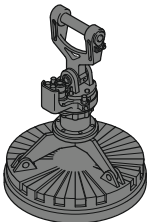

## Magnet devices / lifting magnets

Generator	kW	30
Electromagnet with suspension		
Power	kW	22
Diameter of magnet	mm	1,900
Weight	kg	5,090

# Liebherr ERC-System

## More performance, less consumption

Lowering the equipment stores energy in the ERC-System. This stored energy is then made available to the machine to provide additional engine power. When the equipment is raised the stored energy is released and is reflected in powerful, homogeneous operating cycles. The result is a clear saving on fuel – and, at the same time, even greater performance.

## System performance

The energy recovery cylinder is a storage system which is independent of the diesel engine. The system performance of material handling machines fitted with the ERC-System is composed of the installed engine power and the energy recovery cylinder. When the equipment is raised, energy from the ERC-System is supplied in addition to the power from the diesel engine.

## ERC-System

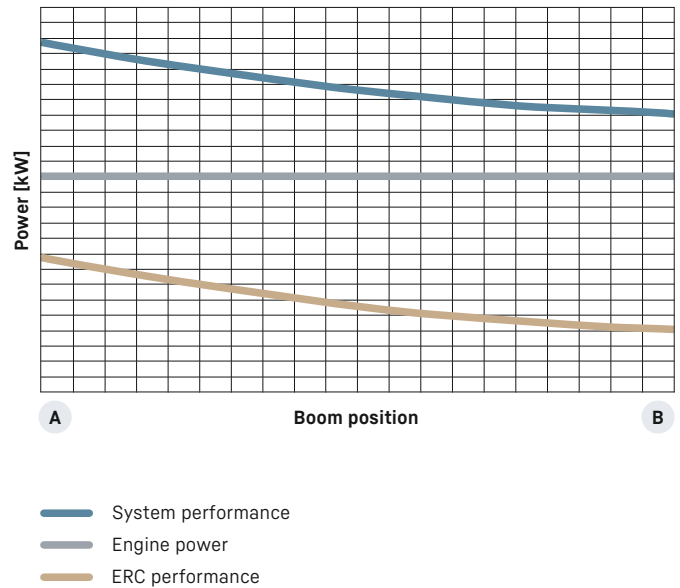

**B** 1. Equipment fitting raised / energy released

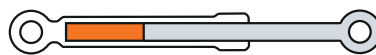

2. Lower equipment fitting / store energy  
4. Raise equipment fitting / release energy



**A** 3. Equipment fitting lowered / energy stored

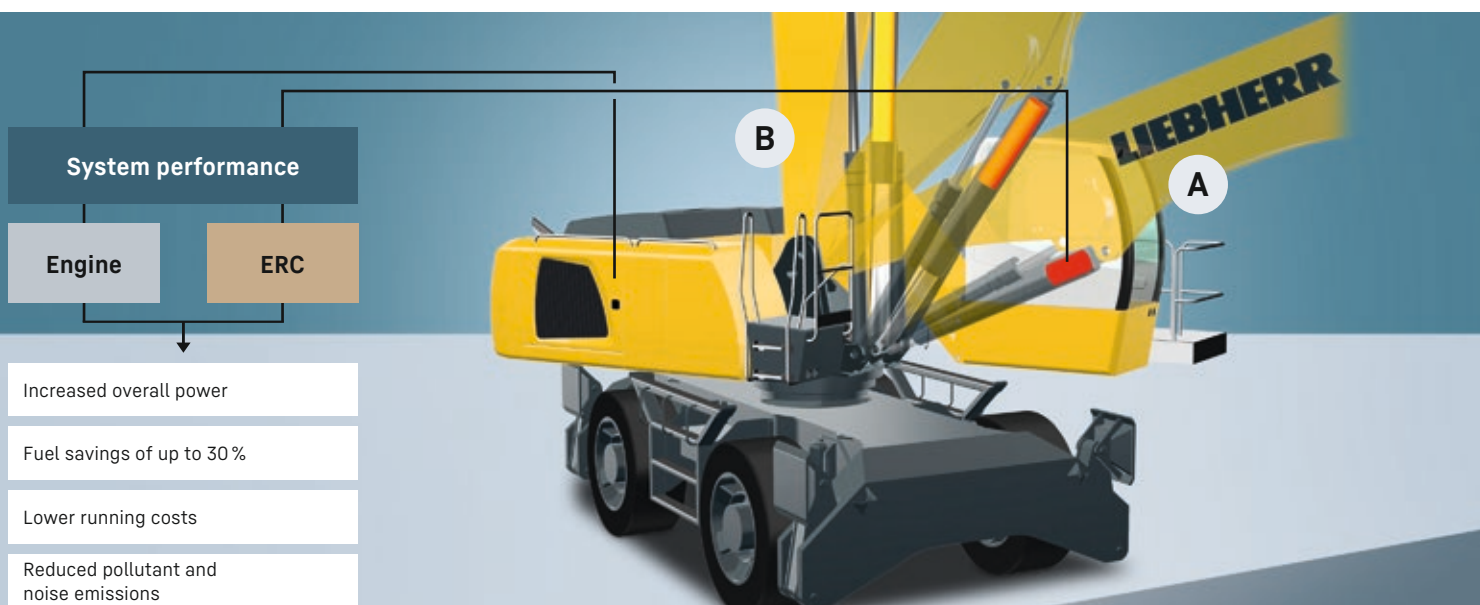



# Equipment



## Undercarriage

	150 M	150 C	150 M HR	150 C HR	150 M Gantry	150 C Gantry
6 steering axles, 2 powered and braked	•					
8 steering axles, 2 powered and braked	+		+		•	
Support plates, variants	+		+		+	
Axle load monitoring	•		•		•	
Working lights on undercarriage, LED	•		•		•	
Track pads, variants		+		+		+
Individual control outriggers	•		•		•	
Three-piece chain guide		•		•		•
Outrigger monitoring system	•		•		•	
Tyres, variants	+		+		+	
Warning beacons	•		•		•	



## Uppercarriage

	150 M	150 C	150 M HR	150 C HR	150 M Gantry	150 C Gantry
Tank refilling pump fuel	+	+	+	+	+	+
Generator	+	+	+	+	+	+
Main battery switch for electrical system	•	•	•	•	•	•
Engine hood, hydraulic operable	•	•	•	•	•	•
Walk-in engine bay	•	•	•	•	•	•
Amber beacon, at uppercarriage, LED double flash	+	+	+	+	+	+
Side hood on the right, hydraulic operable	•	•	•	•	•	•
Tool equipment, extended	•	•	•	•	•	•



## Hydraulic system

	150 M	150 C	150 M HR	150 C HR	150 M Gantry	150 C Gantry
Shut-off valve between hydraulic tank and pump(s)	•	•	•	•	•	•
Pressure test fittings	•	•	•	•	•	•
Accumulator for controlled lowering of the equipment with the engine shut down	•	•	•	•	•	•
Electronic pump regulation	•	•	•	•	•	•
Hydraulic oil filter with integrated microfilter	•	•	•	•	•	•
Liebherr hydraulic oil from -20 °C to +40 °C	•	•	•	•	•	•
Liebherr hydraulic oil, biologically degradable	+	+	+	+	+	+
Liebherr hydraulic oil, specially for warm or cold regions	+	+	+	+	+	+
Magnetic rod in hydraulic tank	•	•	•	•	•	•
Bypass filter	+	+	+	+	+	+
Preheating hydraulic oil	+	+	+	+	+	+



## Engine

	150 M	150 C	150 M HR	150 C HR	150 M Gantry	150 C Gantry
Air pre-filter with dust discharge	+	+	+	+	+	+
Preheating fuel	+	+	+	+	+	+
Preheating coolant	+	+	+	+	+	+
Preheating engine oil*	+	+	+	+	+	+



## Cooling system

	150 M	150 C	150 M HR	150 C HR	150 M Gantry	150 C Gantry
Reversible fan drive	+	+	+	+	+	+



## Cab

	150 M	150 C	150 M HR	150 C HR	150 M Gantry	150 C Gantry
Cab lights rear, LED	•	•	•	•	•	•
Cab lights front, LED (under rain cover)	•	•	•	•	•	•
Armrest adjustable	•	•	•	•	•	•
Circular bubble level	•	•	•	•	•	•
Slewing gear brake Comfort, button on the left or right joystick	+ +	+ +	+ +	+ +	+ +	+ +
Driver profile, personalised (max. 5 drivers)	+ +	+ +	+ +	+ +	+ +	+ +
Operator's seat Comfort	•	•	•	•	•	•
Operator's seat Premium	+ +	+ +	+ +	+ +	+ +	+ +
Driving alarm (acoustic signal is emitted during travel, can not be switched ON / OFF)	+ +	+ +	+ +	+ +	+ +	+ +
Fire extinguisher	•	•	•	•	•	•
Cab elevation, hydraulic with double parallelogram (LHC-D)	+ +	+ +	+ +	+ +	+ +	+ +
Cab elevation, rigid (LFC)	•	•	•	•	•	•
Automatic air conditioning	•	•	•	•	•	•
Electric cooler	•	•	•	•	•	•
LiDAT, vehicle fleet management	•	•	•	•	•	•
Proportional control	•	•	•	•	•	•
Radio Comfort, control via display with handsfree set	+ +	+ +	+ +	+ +	+ +	+ +
Preparation for radio installation	•	•	•	•	•	•
Amber beacon, on cab, LED double flash	+ +	+ +	+ +	+ +	+ +	+ +
Windows made from impact-resistant laminated safety glass (front, roof and bottom window)	•	•	•	•	•	•
Windscreen wiper, roof	+ +	+ +	+ +	+ +	+ +	+ +
Windshield wiper, entire windscreen	•	•	•	•	•	•
FOPS top guard	+ +	+ +	+ +	+ +	+ +	+ +
FGPS front guard	+ +	+ +	+ +	+ +	+ +	+ +
Auxiliary heater programmable	•	•	•	•	•	•



## Equipment

	150 M	150 C	150 M HR	150 C HR	150 M Gantry	150 C Gantry
Boom lights, 2 pieces, LED	•	•	•	•	•	•
Stick lights, 4 pieces, LED	•	•	•	•	•	•
Boom shutoff (retract / extend), electronically	•	•	•	•	•	•
Equipment with electro-hydraulic end position control	•	•	•	•	•	•
AutoLift	+ +	+ +	+ +	+ +	+ +	+ +
Pressure warning mechanism hoist cylinder	•	•	•	•	•	•
ERC system	•	•	•	•	•	•
Boom cylinder cushioning	•	•	•	•	•	•
Stick camera (with separate monitor), bottom side, with protection	+ +	+ +	+ +	+ +	+ +	+ +
Load torque limitation	+ +	+ +	+ +	+ +	+ +	+ +
Pipe fracture safety valves hoist cylinders	•	•	•	•	•	•
Pipe fracture safety valves stick cylinders	•	•	•	•	•	•
Quick coupling system MH 110B	+ +	+ +	+ +	+ +	+ +	+ +
Protection for piston rod, energy recovering cylinder	+ +	+ +	+ +	+ +	+ +	+ +
Protection for piston rods, hoist cylinder	+ +	+ +	+ +	+ +	+ +	+ +
Stick shutoff (retract), electronically	•	•	•	•	•	•
Stick shutoff (retract / extend), electronically	+ +	+ +	+ +	+ +	+ +	+ +
Retract stick without pressure	•	•	•	•	•	•
Sticks with quick coupling	+ +	+ +	+ +	+ +	+ +	+ +
Overload warning device	+ +	+ +	+ +	+ +	+ +	+ +



## Complete machine

	150 M	150 C	150 M HR	150 C HR	150 M Gantry	150 C Gantry
<b>Lubrication</b>						
Central lubrication system for uppercarriage and equipment, automatically	•	•	•	•	•	•
Central lubrication system for undercarriage, automatically	•	•	•	•	•	•
<b>Special coating</b>						
Special coating, variants	+ +	+ +	+ +	+ +	+ +	+ +
<b>Monitoring</b>						
Rear view monitoring with camera	•	•	•	•	•	•
Side view monitoring with camera	•	•	•	•	•	•

- = Standard, + = Option

Options and /or special equipment, supplied by vendors other than Liebherr, are only to be installed with the knowledge and approval of Liebherr in order to retain warranty.

