

LH 26 Industry Litronic

LIEBHERR

Electric material handling machine

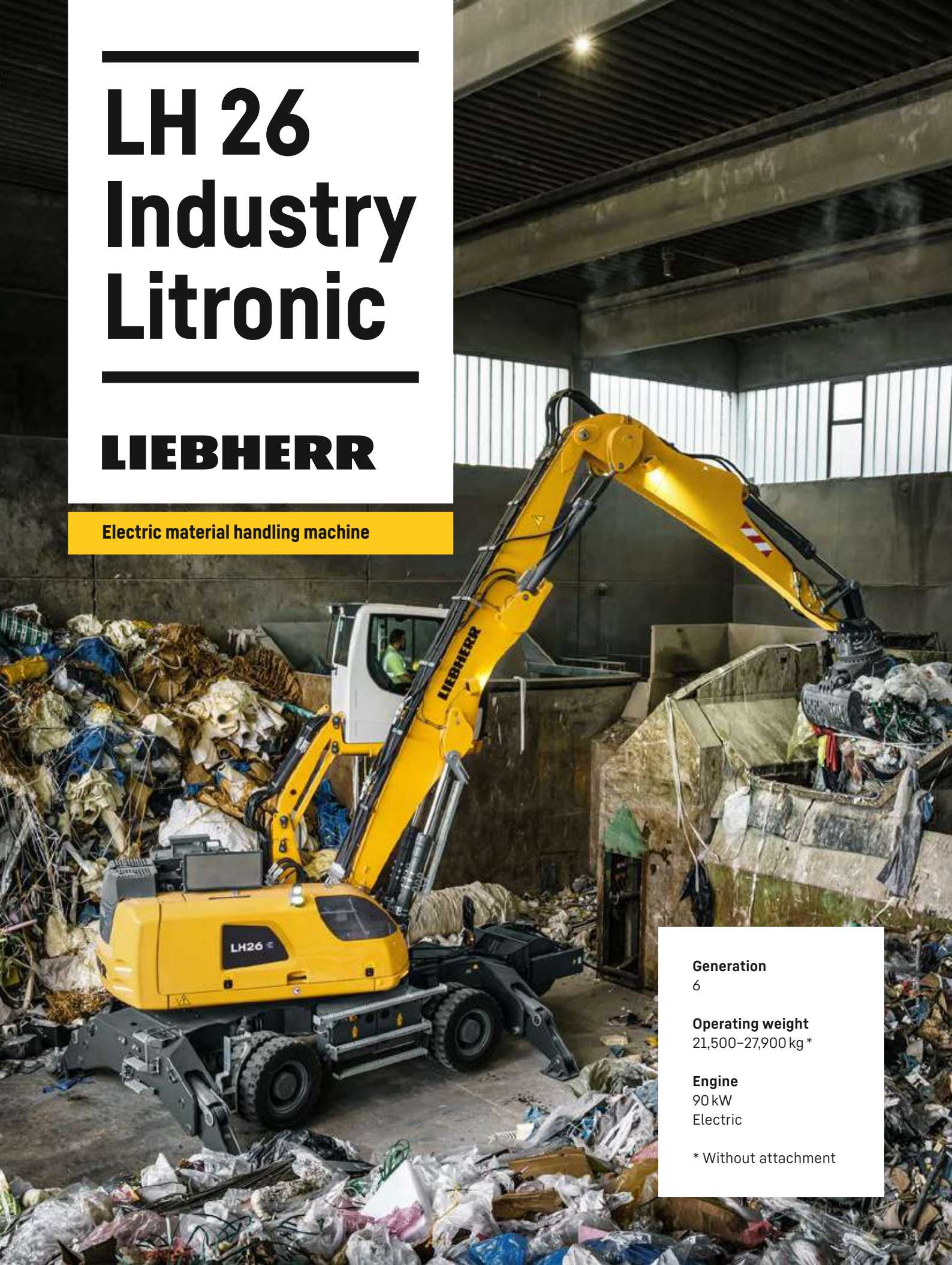

Generation
6

Operating weight
21,500–27,900 kg *

Engine
90 kW
Electric

* Without attachment

Performance

Power plus speed –
redefined performance

Economy

Good investment –
savings for the long-term

Reliability

Durability and sustainability –
quality down to the last detail

Comfort

Perfection at a glance –
when technology is comfortable

Maintainability

Efficiency bonus –
even with maintenance and service





LH 26 M Industry Litronic

Operating weight
26,200–26,500 kg*

Engine
90 kW
Electric

LH 26 C Industry Litronic

Operating weight
26,700–27,900 kg*

Engine
90 kW
Electric

LH 26 P Industry Litronic

Operating weight
21,500–22,500 kg*

Engine
90 kW
Electric

* Without attachment

Well thought out to the last detail





Frequency converters

- Individual adjustment of the speed
- Gentle start to avoid activation current peaks during starting
- Simple adjustment to all conventional power supply networks



Extremely dusty jobs

- Large scale cooler with large mesh for excellent cooling capacity
- Recycling package with reversible fan and separate position of the air conditioning condenser to delay the engine and cooler becoming contaminated and thus ensuring high machine availability



Mobility Kit

- Battery-powered Mobility Kit for temporary, mains-independent operation
- Location-independent operation for maximum flexibility on site



Stationary use

- Four individual levelling outriggers to compensate uneven floors
- Folding outriggers for a transport width of less than 3.0 m
- Low surface pressure due to large support feet
- Maintenance points are safely accessible from the ground

Convincing in operation



Performance

Advanced technology

The frequency converter guarantees the flexibility required by the electric motor to suit the job in hand. As a result of its function as a speed regulator, it enables sensitive, dynamic work movements to be performed and combines precision with speed.

Rapid work cycles

The LH 26 electrical handling machine features the load-sensing control system. This divides the fluid delivered by the pump independently of the load pressures. This, in turn, means that the parallel actuation of multiple consumers, such as moving the equipment or the uppercarriage, does not affect their speed. The benefit is that this makes simultaneous movements possible to achieve a significantly higher handling capacity.

Economy

Sensor controlled low idle automatic

The proven standard sensor controlled automatic low idle reduces the engine speed to idling level as soon as the operator takes his hand off the joystick which means that no hydraulic functions are activated. In addition to saving energy, this also reduces noise.

Optimised running costs

The low maintenance requirement reduces service costs and guarantees high machine availability. The frequency converter technology used on the LH 26 electric significantly reduces electricity costs compared to systems without frequency converters. The reason for this is that the reserve power required for commissioning the machine and the reactive currents whilst the machine is operating are lower.

Mobility Kit

The optional Mobility Kit allows you to change locations or do short, light work independently of mains operation. The battery pack is charged during operations and the electrical energy is stored. When the mains connection is disconnected the handling machine is automatically supplied with electrical energy from the Mobility Kit. The machine can be moved regardless of its location, which ensures maximum flexibility.

Reliability

Quality and competence

Our experience, understanding of customer needs and the technical implementation of these findings guarantee the success of the product. For decades, Liebherr has been inspirational with its depth of production and system solutions. Key components such as the diesel engine and electric motors, electronic components, slewing ring, slewing drives and hydraulic cylinders are developed and produced by Liebherr itself. The extent of in-house manufacturing guarantees maximum quality and ensures that components are optimally configured to each other.

Protecting the components

As a power converter, the frequency converter provides a direct power supply and control for the electric motor by adjusting to the local power supply network and ensures that the motor can be started gently to protect the hydraulic drive components, ensuring that they deliver a long service life.

Working area limit

The handling machine can be fitted with an optional working area limit for jobs which require a limited working area. This can prevent collisions and the resulting component damage.

Comfort

Auxiliary air conditioning system

The standard auxiliary air conditioning system delivers a perfect climate for the cab regardless of the actual ambient conditions. This function is delivered independently of the main motor and is available to the operator at all times.

Ergonomic

The latest cab design delivers excellent conditions for healthy, highly concentrated and productive work in maximum comfort. Both the display unit with touchscreen colour display, the controls and comfort driver's seat are all coordinated to form a perfect ergonomic unit. In addition the ergonomic joysticks allow the machine operation to be both pleasant and precise.

Proportional control system

Precision and the fine control of the handling machine are particularly important for applications such as material sorting or scrap recycling. The machine can master this demanding work with ease thanks to its standard proportional control system.

Maintainability

Low maintenance electric motor

The LH 26 electric combines time-tested technology with a new electric drive concept – low maintenance, low noise and unaffected by statutory emissions standards. The heart of the machine is the 90 kW electric motor which powers the hydraulic pump directly and with infinite variation.

Service-based machine design

The service-based machine design guarantees short maintenance times, thus minimising maintenance costs due to the time it saves. All the maintenance points are easily accessible from the ground and easy to reach due to the large, wide-opening service doors. The enhanced service concept places the maintenance points close to each other and reduces their number to a minimum. This means that service work can be completed even more quickly and efficiently.

Integral maintenance benefits

The completion of maintenance work helps keep the machine fully functional. Maintenance work does, however, mean machine down time which must be minimised. Automatic central lubrication systems for the uppercarriage and equipment as well as optional systems for the undercarriage, rapid change systems and attachments not only make it easier to adhere to the prescribed lubrication intervals and ensure a long service life for the components, but also increase the productivity of the Liebherr LH 26 electric Industry handling machine.

Technical data



Electric motor

Rating	90 kW at 1,800 RPM
Model	Liebherr KGF898/4
Type	Three-phase squirrel cage motor
Secondary electric motor	Electric motor auxiliary equipment (air-conditioning compressor, alternator 24 V) 15 kW
Electrical system energy supply	Liebherr drive components and control cabinets for uppercarriage and undercarriage Liebherr frequency converter fed drive system Heavy-duty version
Manufacturer	Liebherr
Supply voltage	
Low voltage	380 V, 400 V
Frequency	50 / 60 Hz
Engine idling	Sensor controlled
Electrical system	Battery-assisted Control system, lighting, diagnostics system
Voltage	24 V
Batteries	2 x 135 Ah / 12 V
Alternator	Three-phase current 28 V / 140 A

Deviating parameters of the power supply system must always be clarified with Liebherr-Hydraulikbagger GmbH.



Cooling system

Electric motor	Air-cooled Cooling system for hydraulic oil with an infinitely variable, thermostatically controlled fan drive system
-----------------------	--------------------------------------------------------------------------------------------------------------------------



Hydraulic controls

Power distribution	Via control valves with integrated safety valves, simultaneous and independent actuation of chassis, swing drive and equipment
Servo circuit	
Equipment and swing	With hydraulic pilot control and proportional joystick levers
Chassis	With hydraulic proportionally functioning foot pedals or adjusted with plugable levers
Additional functions	Via switch or electro-proportional foot pedals
Proportional control	Proportionally acting transmitters on the joysticks for additional hydraulic functions



Hydraulic system

Hydraulic pump	
For equipment and travel drive	Liebherr axial piston variable displacement pump
Max. flow	390 l/min.
Max. pressure	350 bar
Hydraulic pump regulation and control	Liebherr-Synchron-Comfort-system (LSC) with electronic engine speed sensing regulation, pressure and flow compensation, torque controlled swing drive priority
Hydraulic tank	155 l
Hydraulic system	350 l
Filtration	1 main return filter with integrated partial micro filtration (5 µm)
MODE selection	Adjustment of engine and hydraulic performance via a mode pre-selector to match application, e.g. for especially economical and environmentally friendly operation or for maximum material handling and heavy-duty jobs
S (Sensitive)	Mode for precision work and lifting through very sensitive movements
E (Eco)	Mode for especially economical and environmentally friendly operation
P (Power)	Mode for high performance with low fuel consumption
P+ (Power-Plus)	Mode for highest performance and for very heavy duty applications, suitable for continuous operation
Engine speed and performance setting	Stepless alignment of engine output and hydraulic power via engine speed
Option	Tool Control: 20 pre-adjustable pump flows and pressures for add-on attachments



Swing drive

Drive	Liebherr axial piston motor with integrated brake valve and torque control
Swing ring	Liebherr, sealed race ball bearing swing ring, internal teeth
Swing speed	0-9.0 RPM stepless
Swing torque	53 kNm
Holding brake	Wet multi-disc (spring applied, pressure released)
Option	Slewing gear brake Comfort

Cab

Cab	TOPS safety cab structure (tip-over protection) with individual windscreens or featuring a slide-in subpart under the ceiling, work headlights integrated in the ceiling, a door with a sliding window (can be opened on both sides), large stowing and depositing possibilities, shock-absorbing suspension, sound damping insulating, tinted laminated safety glass, separate shades for the sunroof window and windscreen
Operator's seat Comfort	Air cushioned operator's seat with 3D-adjustable armrests, headrest, lap belt, seat heater, adjustable seat cushion inclination and length, lockable horizontal suspension, automatic weight adjustment, adjustable suspension stiffness, pneumatic lumbar vertebrae support and passive seat climatisation with active coal
Operator's seat Premium (Option)	In addition to operator's seat comfort: active electronic weight adjustment (automatic readjustment), pneumatic low frequency suspension and active seat climatisation with active coal and ventilator
Arm consoles	Joysticks with control consoles and swivel seat, folding left control console
Operation and displays	Large high-resolution operating unit, self-explanatory, colour display with touchscreen, video-compatible, numerous setting, control and monitoring options, e.g. air conditioning control, energy consumption, machine and attachment parameters
Air-conditioning	Automatic air-conditioning, recirculated air function, fast de-icing and demisting at the press of a button, air vents can be operated via a menu; recirculated air and fresh air filters can be easily replaced and are accessible from the outside; heating-cooling unit, designed for extreme outside temperatures, sensors for solar radiation, inside and outside temperatures, stationary air conditioning function with external climate condenser - controlled by a weekly timer
Refrigerant	R134a
Global warming potential	1,430
Quantity at 25 °C*	1,300-1,500 g
CO ₂ equivalent*	1.859-2.145 t
Vibration emission**	
Hand / arm vibrations	< 2.5 m/s ²
Whole-body vibrations	< 0.5 m/s ²
Measuring inaccuracy	According with standard EN 12096:1997

Undercarriage

Mobile	
Drive	Oversized two speed power shift transmission with additional creeper speed, Liebherr axial piston motor with functional brake valve on both sides
Travel speed	0-3.2 km/h stepless
Joystick steering	(creeper speed + transmission stage 1)
Wheel steering (Option)	0-3.2 km/h stepless
	(creeper speed + transmission stage 1)
Driving operation	Automotive driving using accelerator pedal, cruise control function: storage of variable accelerator pedal positions
Axles	40 t drive axles; manual or automatic hydraulically controlled front axle oscillation lock
Service brake	Two circuit travel brake system with accumulator; wet and backlash-free disc brake
Holding brake	Wet multi-disc (spring applied, pressure released)
Stabilization	Stabilizing blade + 2 point outriggers 4 point outriggers
Crawler	
Version	LC
Drive	Liebherr compact planetary reduction gear with Liebherr axial piston motor per side of undercarriage
Travel speed	0-3.2 km/h stepless (creeper speed)
Brake	Functional brake valves on both sides
Holding brake	Wet multi-disc (spring applied, pressure released)
Track pads	Triple grouser
Pedestal	
Stabilization	X-shaped 4-point outriggers with vertical, individual outrigger levelling complete with support plates with ball joint (removable)

Equipment

Type	High-strength steel plates at highly-stressed points for the toughest requirements. Complex and stable mountings of equipment and cylinders
Hydraulic cylinders	Liebherr cylinders with special sealing and guide system and, depending on cylinder type, shock absorption
Bearings	Sealed, low maintenance

Complete machine

Lubrication	Liebherr central lubrication system for uppercarriage and equipment, automatically
Steps system	Safe and durable access system with anti-slip steps; main components hot-galvanised
Noise emission	
ISO 6396	70 dB(A) = L _{PA} (inside cab)
2000/14/EC	99 dB(A) = L _{WA} (surround noise)

* depending on configuration

** for risk assessment according to 2002/44/EC see ISO/TR 25398:2006

LH 26 M – Dimensions

Trailing cable

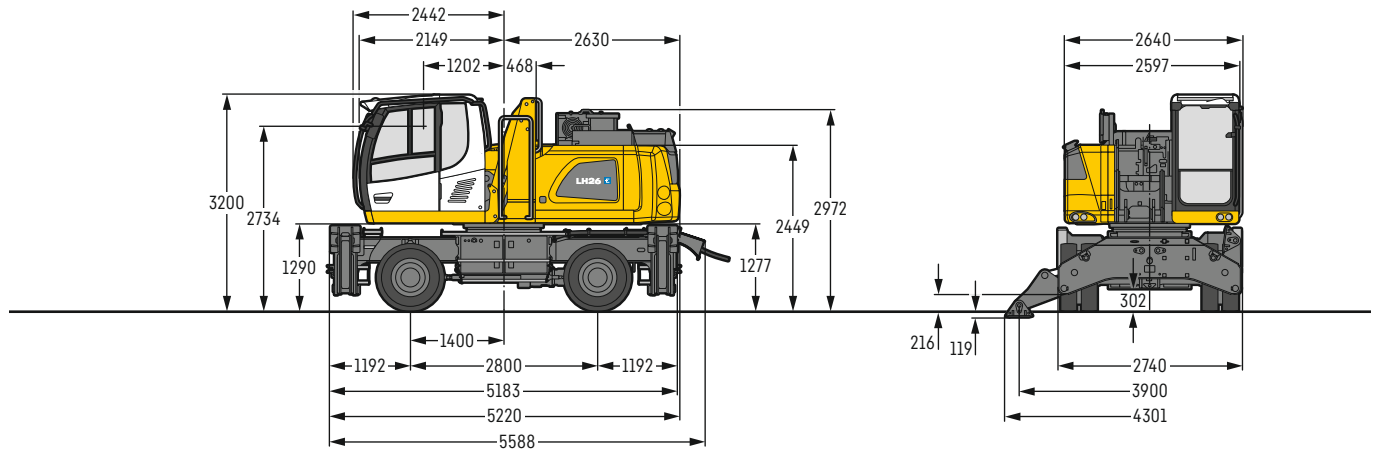

Cable reel system

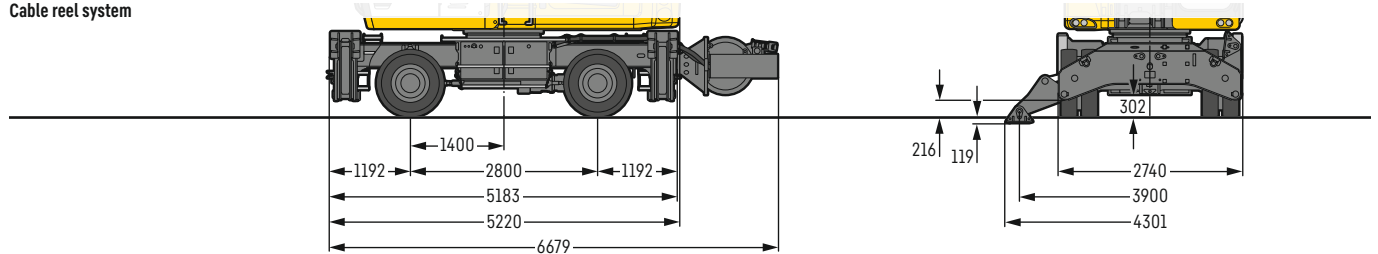

LH 26 M – Choice of cab elevation

Cab elevation LFC 120 (rigid elevation)

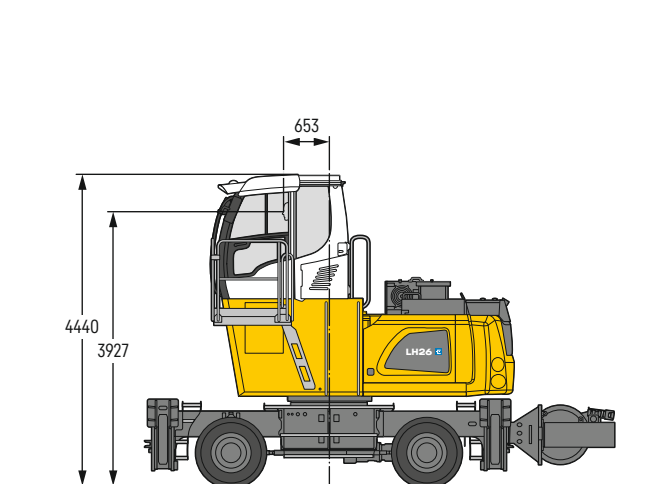

A rigid cab elevation has a fixed eye level height. For a lower transport height, the shell of the cab can be removed and replaced by a transport device. The dimension 4,440 mm is in this machine design for all rigid cab elevations 3,544 mm.

Cab elevation LHC 255 (hydraulic elevation)

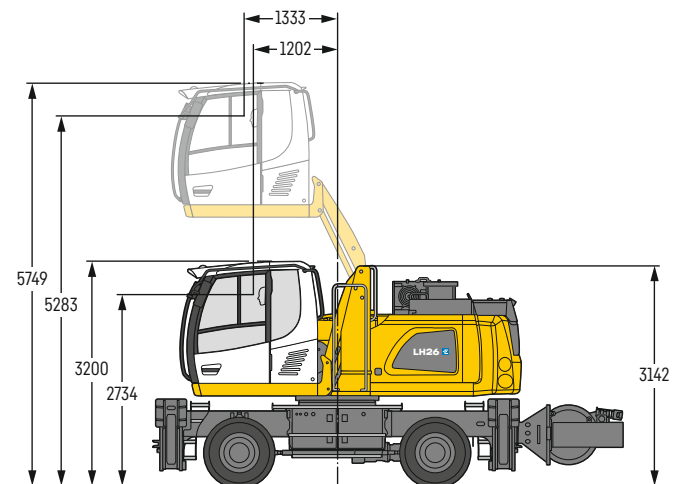

The hydraulically adjustable cab allows the driver, that he can choose his field of view freely and at any time within the stroke.

Tyres 10.00-20

LH 26 C – Dimensions

Trailing cable

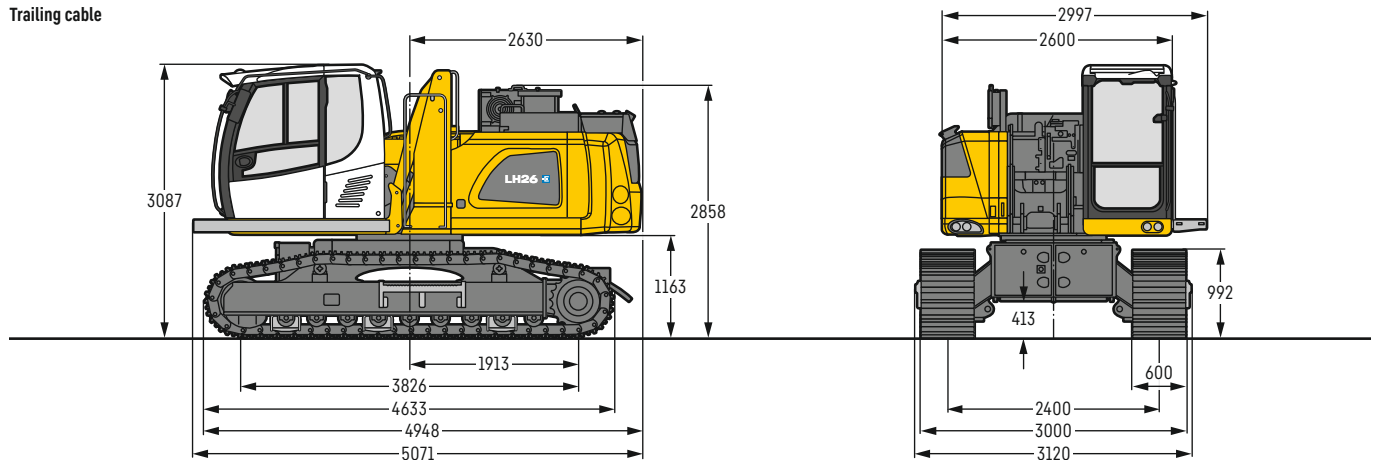

Cable reel system

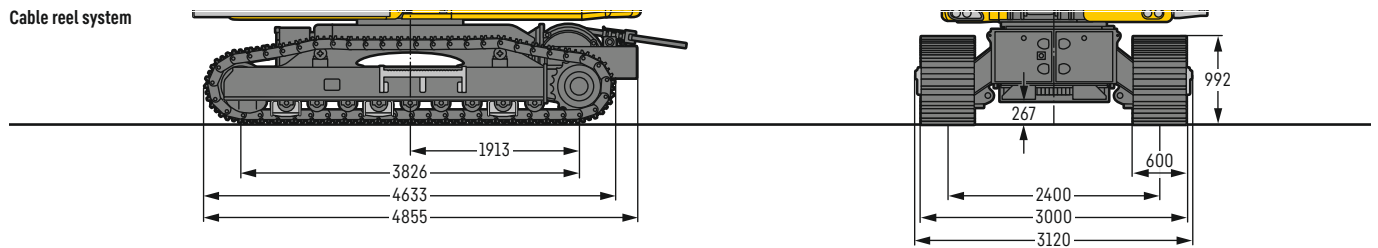

LH 26 C – Choice of cab elevation

**Cab elevation LFC 120
(rigid elevation)**

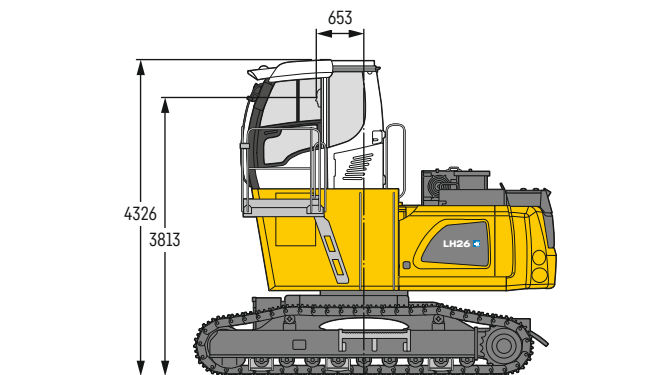

A rigid cab elevation has a fixed eye level height. For a lower transport height, the shell of the cab can be removed and replaced by a transport device. The dimension 4,326 mm is in this machine design for all rigid cab elevations 3,430 mm.

**Cab elevation LHC 255
(hydraulic elevation)**

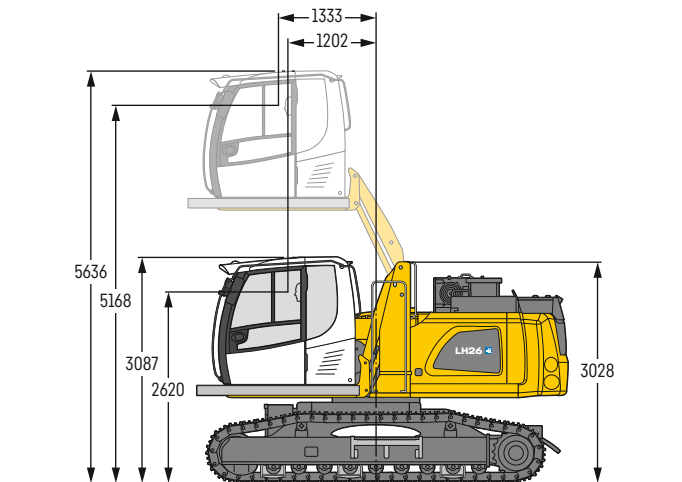

The hydraulically adjustable cab allows the driver, that he can choose his field of view freely and at any time within the stroke.

LH 26 P – Dimensions

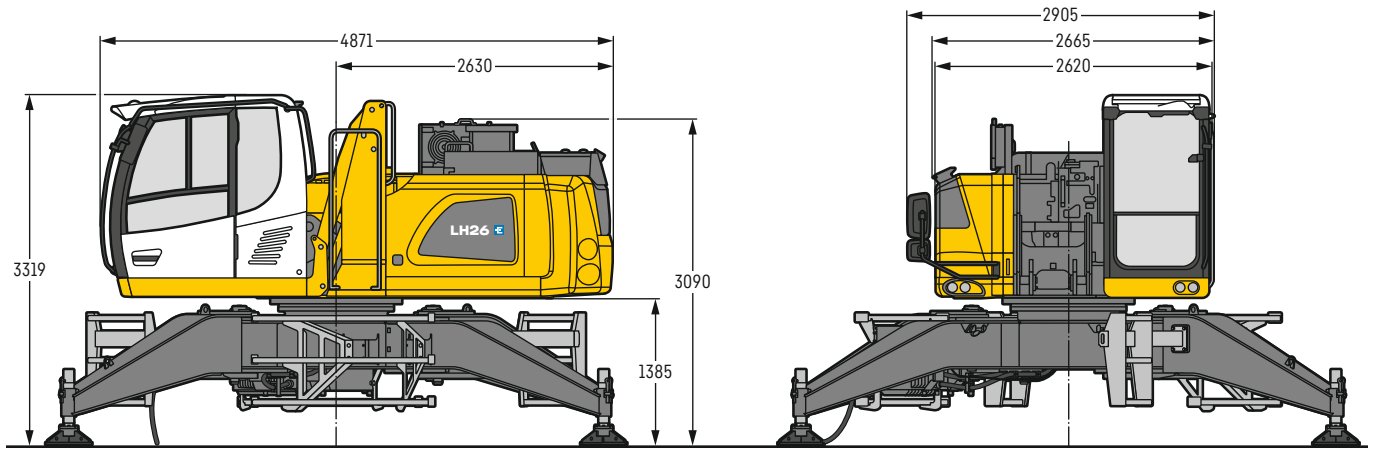

LH 26 P – Choice of cab elevation

**Cab elevation LFC 120
(rigid elevation)**

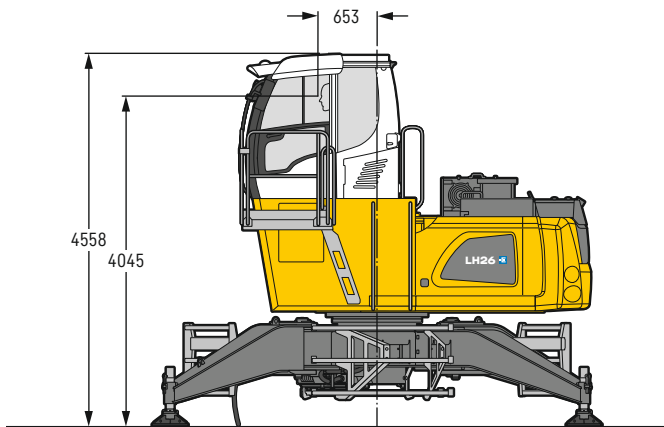

A rigid cab elevation has a fixed eye level height. For a lower transport height, the shell of the cab can be removed and replaced by a transport device. The dimension 4,558 mm is in this machine design for all rigid cab elevations 3,662 mm.

**Cab elevation LHC 255
(hydraulic elevation)**

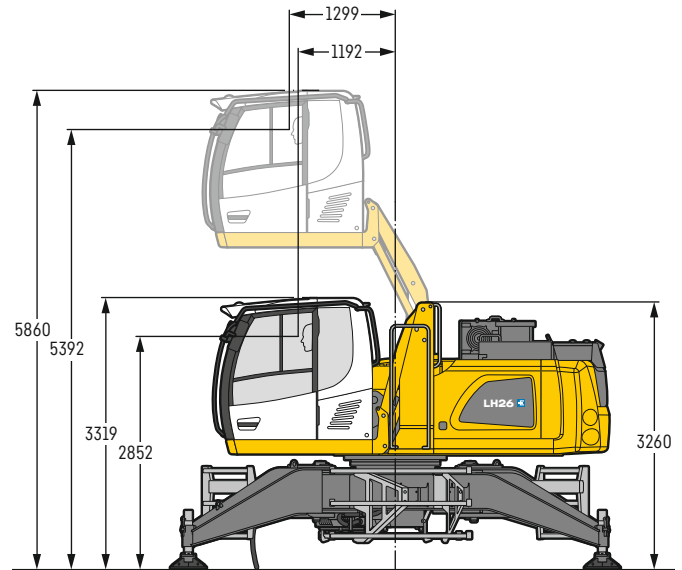

The hydraulically adjustable cab allows the driver, that he can choose his field of view freely and at any time within the stroke.

LH 26 P – Dimensions working position

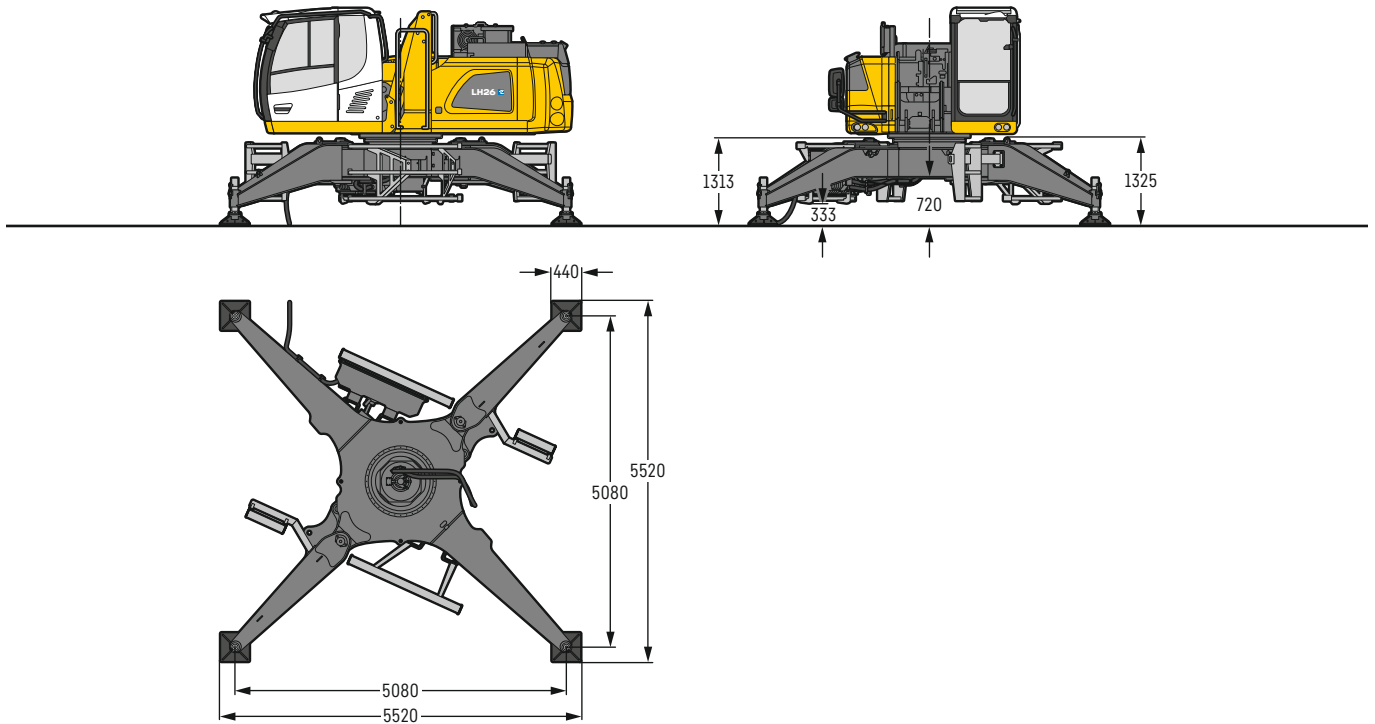

LH 26 P – Dimensions transport position

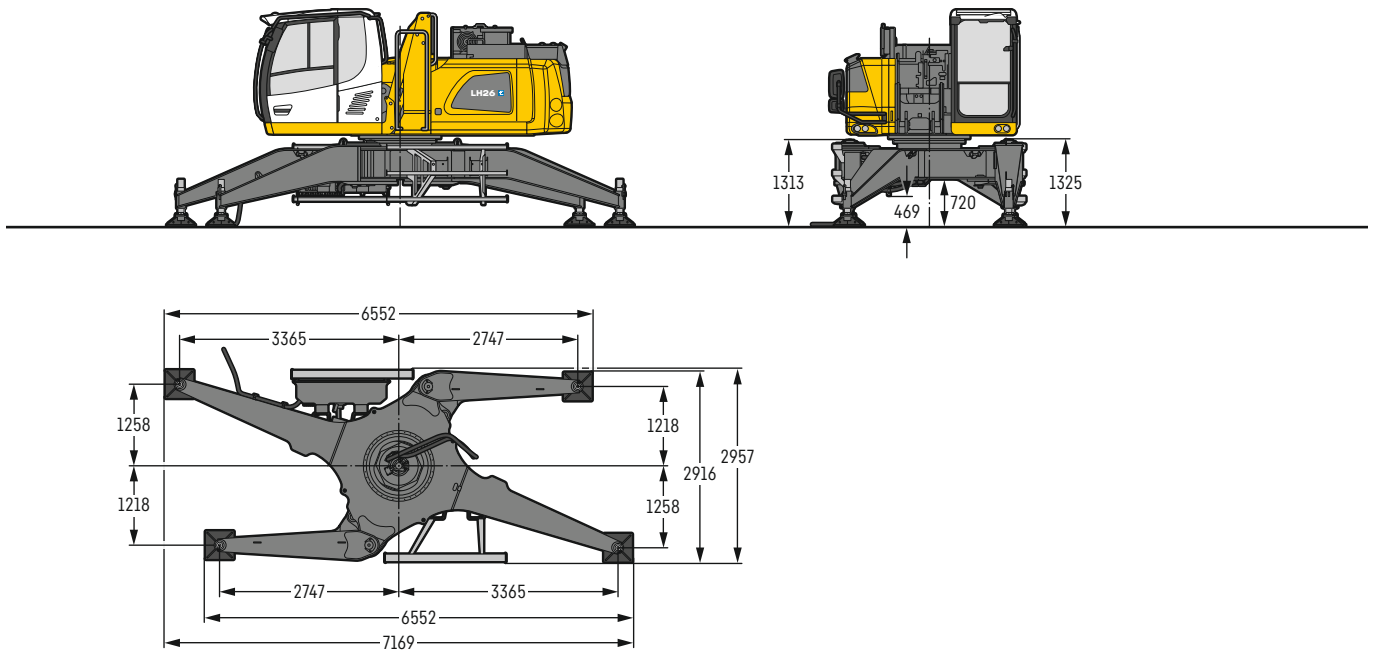

LH 26 M – Equipment GA12

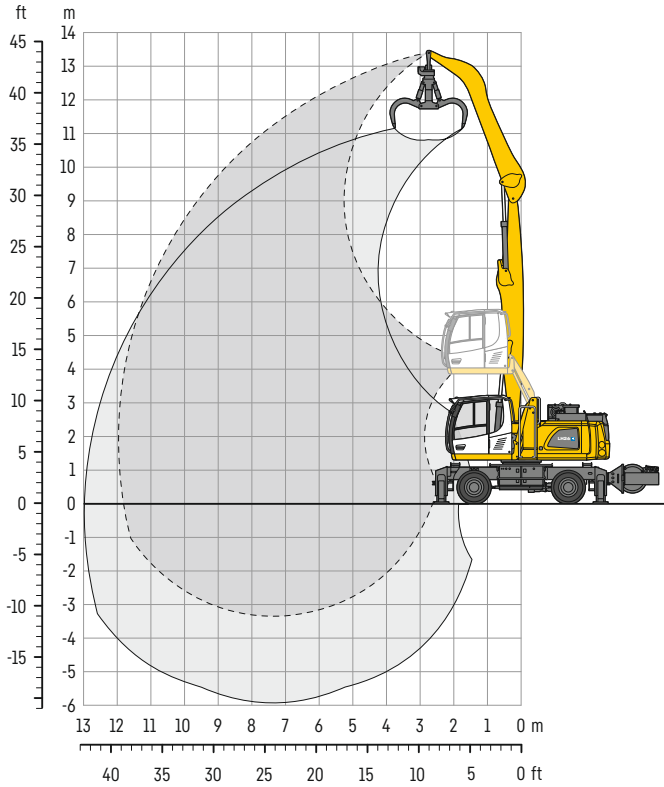

Dimensions

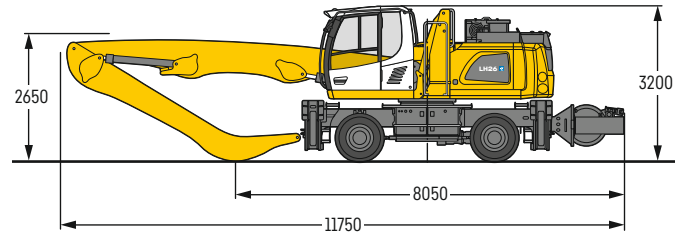

Operating weight

The operating weight includes the basic machine with 4 point outriggers, hydr. cab elevation, 8 solid tyres plus intermediate rings, straight boom 7.10 m, angled stick 5.00 m and multi-tine grab GM 65 / 0.60 m³ semi-closed tines.

Weight 27,100 kg

m	3.0m		4.5m		6.0m		7.5m		9.0m		10.5m		12.0m		m		
	Stabilizers raised	4 pt. outriggers down	Stabilizers raised	4 pt. outriggers down	Stabilizers raised	4 pt. outriggers down	Stabilizers raised	4 pt. outriggers down	Stabilizers raised	4 pt. outriggers down	Stabilizers raised	4 pt. outriggers down	Stabilizers raised	4 pt. outriggers down	Stabilizers raised	4 pt. outriggers down	
13.5																	
12.0			6.5*	6.5*	5.1	5.1*									4.6*	4.6*	6.3
10.5					5.3	6.3*	3.6	4.9							3.0	3.9*	8.3
9.0					5.4	6.8*	3.7	4.9	2.7	3.6					2.3	3.2	9.6
7.5					5.3	6.9*	3.7	4.9	2.7	3.6	2.0	2.7			1.9	2.7	10.6
6.0			7.7*	7.7*	5.1	6.8	3.5	4.8	2.6	3.5	2.0	2.7			1.7	2.4	11.3
4.5	8.5*	8.5*	7.3	10.0*	4.7	6.4	3.3	4.6	2.5	3.4	1.9	2.7			1.6	2.2	11.7
3.0	4.0*	4.0*	6.4	9.2	4.3	6.0	3.1	4.3	2.4	3.3	1.8	2.6			1.5	2.1	11.9
1.5	0.9*	0.9*	5.7	8.2*	3.9	5.5	2.9	4.1	2.2	3.1	1.8	2.5			1.4	2.1	12.0
0	1.5*	1.5*	5.2*	5.2*	3.6	5.2*	2.7	3.9	2.1	3.0	1.7	2.5			1.4	2.1	11.8
-1.5			5.1	5.3*	3.5	5.1	2.6	3.8	2.1	3.0	1.7	2.4			1.5	2.2	11.2
-3.0			5.3*	5.3*	3.4	5.1	2.6	3.7	2.0	2.9					2.0	2.9	9.1

Height Can be slewed through 360° In longitudinal position of undercarriage Max. reach * Limited by hydr. capacity

The lift capacities on the stick end without attachment are stated in metric tons (t) and are valid on a firm, level supporting surface with blocked oscillating axle. These capacities can be slewed through 360° with the undercarriage in the transverse position. Capacities in the longitudinal position of the undercarriage (±15°) are specified over the steering axle with the stabilizers raised and over the rigid axle with the stabilizers down. Indicated loads based on the ISO 10567 standard and do not exceed 75% of tipping or 87% of hydraulic capacity. The lift capacity of the unit is limited by its stability, the lifting capability of the hydraulic elements, or the maximum permissible lifting capacity of the load hook.

In accordance with the harmonised European Standard EN 474-5, hydraulic excavators used for lifting operations must be equipped with pipe fracture safety valves, an overload warning device, a load hook and a lift capacity chart.

LH 26 M – Equipment GA13

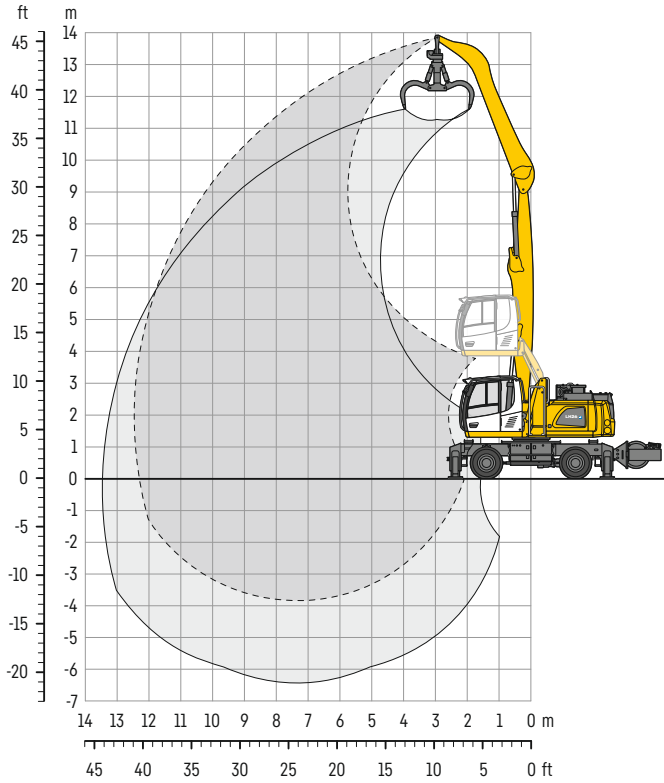

Dimensions

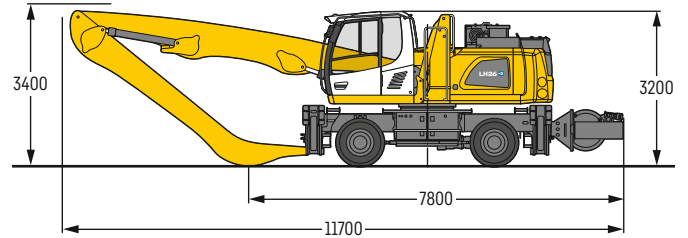

Operating weight

The operating weight includes the basic machine with 4 point outriggers, hydr. cab elevation, 8 solid tyres plus intermediate rings, straight boom 7.10 m, angled stick 5.50 m and multi-tine grab GM 65 / 0.60 m³ semi-closed tines.

Weight 27,200 kg

m	3.0m		4.5m		6.0m		7.5m		9.0m		10.5m		12.0m		m		
	Stabilizers raised	4 pt. outriggers down	Stabilizers raised	4 pt. outriggers down	Stabilizers raised	4 pt. outriggers down	Stabilizers raised	4 pt. outriggers down	Stabilizers raised	4 pt. outriggers down	Stabilizers raised	4 pt. outriggers down	Stabilizers raised	4 pt. outriggers down	Stabilizers raised	4 pt. outriggers down	
13.5															5.4*	5.4*	4.3
12.0					5.3	5.3*									3.8	4.0*	7.2
10.5					5.5	6.0*	3.8	5.0	2.6	3.4*					2.6	3.4*	9.0
9.0					5.5	6.3*	3.8	5.0	2.7	3.7					2.1	2.9	10.2
7.5					5.4	6.6*	3.8	5.0	2.7	3.7	2.0	2.8			1.8	2.5	11.1
6.0					5.2	6.9*	3.6	4.8	2.7	3.6	2.0	2.8			1.6	2.2	11.8
4.5			7.6	8.1*	4.9	6.6	3.4	4.6	2.5	3.5	1.9	2.7	1.5	2.1	1.4	2.1	12.2
3.0	12.3	16.5*	6.7	9.5	4.4	6.1	3.2	4.4	2.4	3.3	1.8	2.6	1.5	2.1	1.4	2.0	12.4
1.5	1.6*	1.6*	5.8	8.5	4.0	5.6	2.9	4.1	2.2	3.2	1.8	2.5	1.4	2.0	1.3	1.9	12.5
0	1.7*	1.7*	5.3	5.8*	3.6	5.3	2.7	3.9	2.1	3.0	1.7	2.4	1.4	2.0	1.3	1.9	12.3
-1.5	2.5*	2.5*	5.0	5.4*	3.4	5.1	2.6	3.7	2.0	2.9	1.6	2.4			1.4	2.0	11.8
-3.0			5.0	5.9*	3.4	5.0	2.5	3.7	2.0	2.9			3.0*	3.0*	1.7	2.5	10.2

Height Can be slewed through 360° In longitudinal position of undercarriage Max. reach * Limited by hydr. capacity

The lift capacities on the stick end without attachment are stated in metric tons (t) and are valid on a firm, level supporting surface with blocked oscillating axle. These capacities can be slewed through 360° with the undercarriage in the transverse position. Capacities in the longitudinal position of the undercarriage (±15°) are specified over the steering axle with the stabilizers raised and over the rigid axle with the stabilizers down. Indicated loads based on the ISO 10567 standard and do not exceed 75% of tipping or 87% of hydraulic capacity. The lift capacity of the unit is limited by its stability, the lifting capability of the hydraulic elements, or the maximum permissible lifting capacity of the load hook.

In accordance with the harmonised European Standard EN 474-5, hydraulic excavators used for lifting operations must be equipped with pipe fracture safety valves, an overload warning device, a load hook and a lift capacity chart.

LH 26 M – Equipment GK11

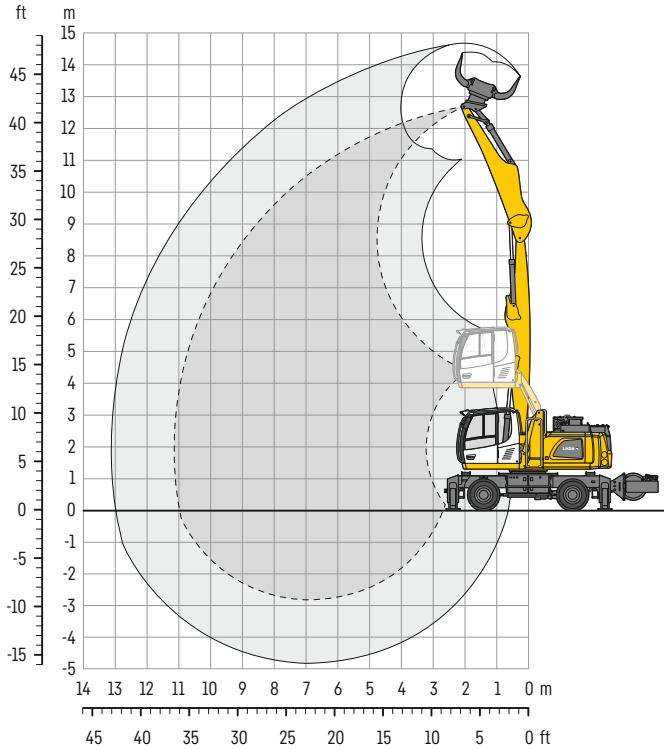

Dimensions

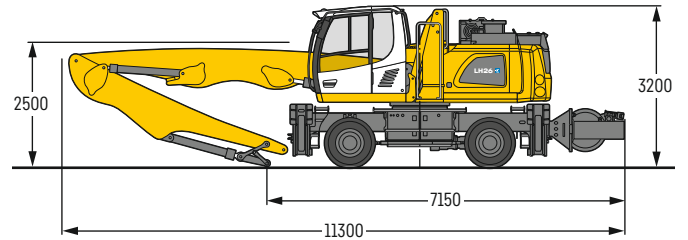

Operating weight

The operating weight includes the basic machine with 4 point outriggers, hydr. cab elevation, 8 solid tyres plus intermediate rings, straight boom 6.60m, stick with tipping kinematics 4.50m and sorting grab SG 25B/0.55 m² perforated shells.

Weight 27,000kg

m	Undercarriage	3.0m		4.5m		6.0m		7.5m		9.0m		10.5m		12.0m		m		
12.0	Stabilizers raised			6.4*	6.4*											6.3*	6.3*	4.5
	4 pt. outriggers down			6.4*	6.4*											6.3*	6.3*	
10.5	Stabilizers raised			7.6*	7.6*	4.9	6.4*									3.6	4.6*	7.1
	4 pt. outriggers down			7.6*	7.6*	6.4*	6.4*									4.6*	4.6*	
9.0	Stabilizers raised					5.0	6.7	3.4	4.6							2.5	3.5	8.6
	4 pt. outriggers down					6.9*	6.9*	6.0*	6.0*							4.0*	4.0*	
7.5	Stabilizers raised					5.0	6.7	3.4	4.6	2.4	3.3					2.0	2.9	
	4 pt. outriggers down					6.9*	6.9*	5.9*	5.9*	5.1	5.2*					3.7*	3.7*	9.7
6.0	Stabilizers raised			7.7	7.9*	4.8	6.5	3.3	4.5	2.4	3.3					1.7	2.5	10.4
	4 pt. outriggers down			7.9*	7.9*	7.2*	7.2*	6.0*	6.0*	5.1	5.2*					3.5*	3.5*	
4.5	Stabilizers raised	7.1*	7.1*	7.1	9.9	4.5	6.2	3.1	4.3	2.3	3.2	1.7	2.4			1.6	2.3	10.9
	4 pt. outriggers down	7.1*	7.1*	9.9*	9.9*	7.7*	7.7*	6.2*	6.2*	5.0	5.2*	3.9	4.2*			3.5*	3.5*	
3.0	Stabilizers raised			6.3	9.0	4.1	5.8	2.9	4.1	2.2	3.1	1.6	2.4			1.5	2.2	11.1
	4 pt. outriggers down			11.0*	11.0*	8.1*	8.1*	6.4*	6.4*	4.9	5.2*	3.8	4.1*			3.5	3.5*	
1.5	Stabilizers raised			5.6	8.3	3.8	5.4	2.7	3.9	2.1	3.0	1.6	2.3			1.4	2.1	11.1
	4 pt. outriggers down			9.2*	9.2*	8.2*	8.2*	6.3	6.3*	4.8	5.0*	3.8	3.8*			3.1*	3.1*	
0	Stabilizers raised	1.0*	1.0*	5.2	5.6*	3.5	5.2	2.6	3.8	2.0	2.9	1.6	2.3			1.5	2.2	11.0
	4 pt. outriggers down	1.0*	1.0*	5.6*	5.6*	7.7*	7.7*	5.9*	5.9*	4.6*	4.6*	3.3*	3.3*			2.7*	2.7*	
-1.5	Stabilizers raised			5.1	6.0*	3.4	5.0	2.5	3.7	1.9	2.8					1.7	2.5	10.0
	4 pt. outriggers down			6.0*	6.0*	6.6*	6.6*	5.1*	5.1*	3.8*	3.8*					2.9*	2.9*	

Height Can be slewed through 360° In longitudinal position of undercarriage Max. reach * Limited by hydr. capacity

The lift capacities on the stick end without attachment are stated in metric tons (t) and are valid on a firm, level supporting surface with blocked oscillating axle. These capacities can be slewed through 360° with the undercarriage in the transverse position. Capacities in the longitudinal position of the undercarriage (±15°) are specified over the steering axle with the stabilizers raised and over the rigid axle with the stabilizers down. Indicated loads based on the ISO 10567 standard and do not exceed 75% of tipping or 87% of hydraulic capacity. The lift capacity of the unit is limited by its stability, the lifting capability of the hydraulic elements, or the maximum permissible lifting capacity of the load hook.

In accordance with the harmonised European Standard EN 474-5, hydraulic excavators used for lifting operations must be equipped with pipe fracture safety valves, an overload warning device, a load hook and a lift capacity chart.

LH 26 M – Equipment VK9

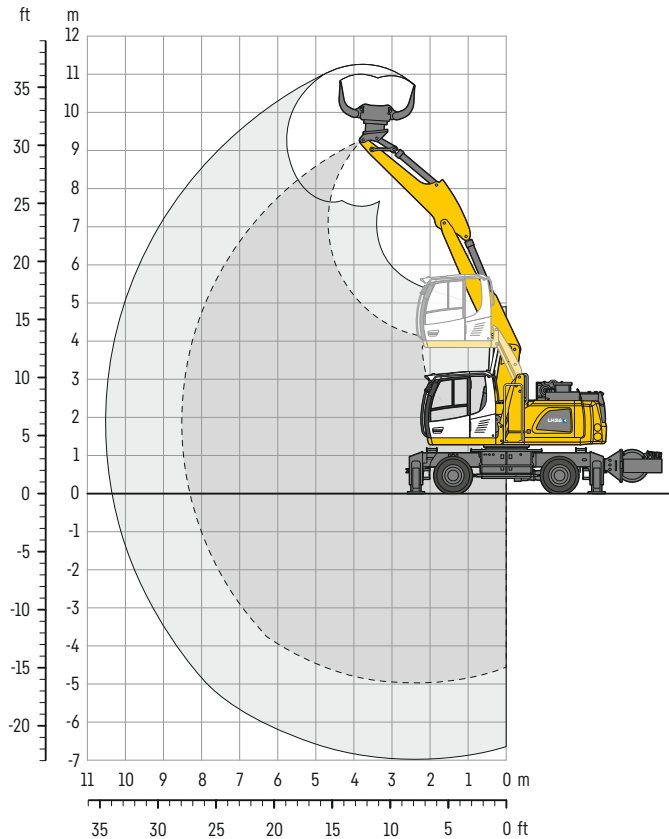

Dimensions

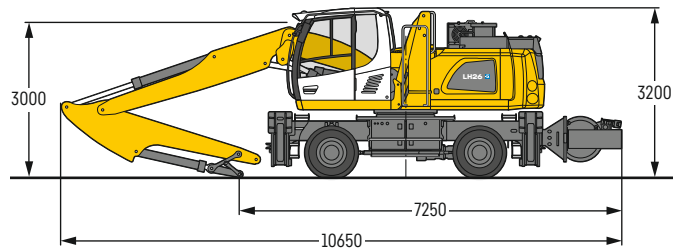

Operating weight

The operating weight includes the basic machine with 4 point outriggers, hydr. cab elevation, 8 solid tyres plus intermediate rings, two-piece boom 5.40 m (HD), stick with tipping kinematics 3.05 m and sorting grab SG 25B / 0.55 m² perforated shells.

Weight 27,000 kg

m	Undercarriage	3.0m		4.5m		6.0m		7.5m		9.0m		10.5m		12.0m		m		
9.0	Stabilizers raised															3.6*	3.6*	4.4
	4 pt. outriggers down															3.6*	3.6*	
7.5	Stabilizers raised					3.7*	3.7*									2.9*	2.9*	6.3
	4 pt. outriggers down					3.7*	3.7*									2.9*	2.9*	
6.0	Stabilizers raised			5.0*	5.0*	4.9*	4.9*									2.7*	2.7*	7.4
	4 pt. outriggers down			5.0*	5.0*	4.9*	4.9*									2.7*	2.7*	
4.5	Stabilizers raised			6.3*	6.3*	5.0	5.9*	3.5	4.5*							2.6*	2.6*	8.1
	4 pt. outriggers down			6.3*	6.3*	5.9*	5.9*	4.5*	4.5*							2.6*	2.6*	
3.0	Stabilizers raised	12.9	13.7*	7.3	8.8*	4.9	6.4	3.5	4.6							2.7*	2.7*	8.5
	4 pt. outriggers down	13.7*	13.7*	8.8*	8.8*	6.7*	6.7*	5.6*	5.6*							2.7*	2.7*	
1.5	Stabilizers raised	12.6	13.1*	7.1	9.4	4.9	6.3	3.4	4.6							2.7	2.8*	8.5
	4 pt. outriggers down	13.1*	13.1*	10.1*	10.1*	7.3*	7.3*	5.8*	5.8*							2.8*	2.8*	
0	Stabilizers raised	12.7	14.7*	7.2	9.4	4.8	6.4	3.3	4.4							2.7	3.2*	8.3
	4 pt. outriggers down	14.7*	14.7*	10.4*	10.4*	7.5*	7.5*	5.9*	5.9*							3.2*	3.2*	
-1.5	Stabilizers raised	12.6	16.7*	7.0	9.6	4.5	6.2	3.1	4.3							2.9	3.8*	7.8
	4 pt. outriggers down	16.7*	16.7*	10.5*	10.5*	7.6*	7.6*	5.3*	5.3*							3.8*	3.8*	
-3.0	Stabilizers raised	12.4	17.3*	6.7	9.4	4.3	6.0									3.5	4.4*	6.9
	4 pt. outriggers down	17.3*	17.3*	10.8*	10.8*	7.0*	7.0*									4.4*	4.4*	
-4.5	Stabilizers raised	12.1	13.8*	6.4	6.9*											5.8*	5.8*	4.8
	4 pt. outriggers down	13.8*	13.8*	6.9*	6.9*											5.8*	5.8*	

Height Can be slewed through 360° In longitudinal position of undercarriage Max. reach * Limited by hydr. capacity

The lift capacities on the stick end without attachment are stated in metric tons (t) and are valid on a firm, level supporting surface with blocked oscillating axle. These capacities can be slewed through 360° with the undercarriage in the transverse position. Capacities in the longitudinal position of the undercarriage ($\pm 15^\circ$) are specified over the steering axle with the stabilizers raised and over the rigid axle with the stabilizers down. The values apply with the optimum positioning of the two-piece boom. Indicated loads based on the ISO 10567 standard and do not exceed 75% of tipping or 87% of hydraulic capacity. The lift capacity of the unit is limited by its stability, the lifting capability of the hydraulic elements, or the maximum permissible lifting capacity of the load hook. In accordance with the harmonised European Standard EN 474-5, hydraulic excavators used for lifting operations must be equipped with pipe fracture safety valves, an overload warning device, a load hook and a lift capacity chart.

LH 26 C – Equipment GA10

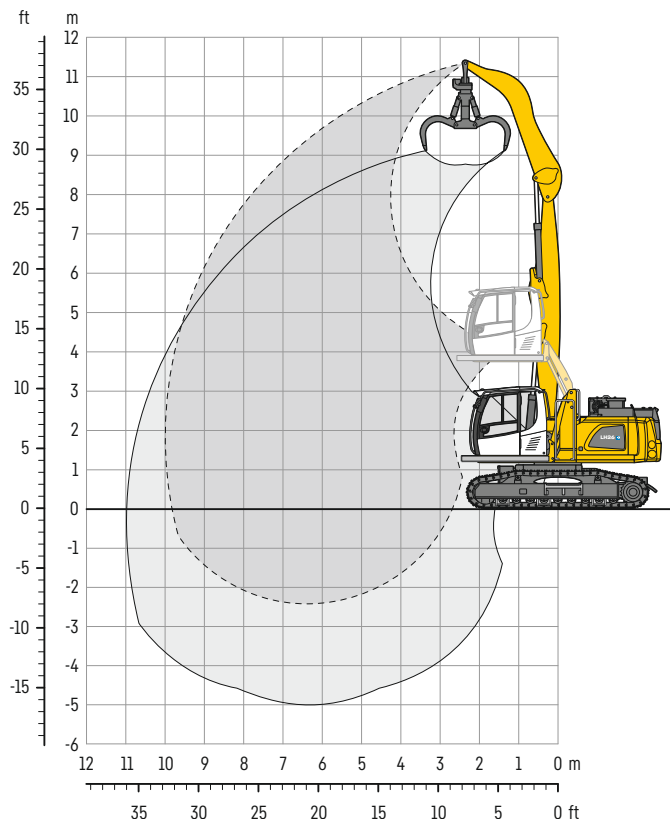

Dimensions

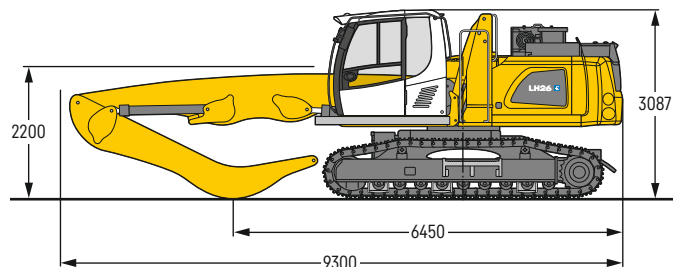

Operating weight and ground pressure

The operating weight includes the basic machine with hydr. cab elevation, straight boom 6.10 m, angled stick 4.00 m and multi-tine grab GM 65/0.60 m³ semi-closed tines.

Weight	28,400 kg
Pad width	600 mm
Ground pressure	on request

m	Undercarriage	3.0m		4.5m		6.0m		7.5m		9.0m		10.5m		12.0m		Max. reach		m	
		LC	LC	LC	LC	LC	LC	LC	LC	LC	LC	LC	LC	LC	LC	LC	LC		
12.0	LC																		
10.5	LC			6.5*	6.5*												6.1*	6.1*	4.7
9.0	LC			8.2*	8.2*	6.7*	6.7*										5.0*	5.0*	6.8
7.5	LC			8.9*	8.9*	7.2	7.6*	5.1	6.3*								4.4	4.5*	8.2
6.0	LC			9.5*	9.5*	7.1	7.8*	5.0	6.6*	3.8	4.6*						3.7	4.3*	9.1
4.5	LC	11.3*	11.3*	10.4*	10.4*	6.8	8.2*	4.9	6.7*	3.7	5.6*						3.4	4.3*	9.6
3.0	LC	14.9*	14.9*	9.9	11.5*	6.5	8.6*	4.8	6.8*	3.7	5.6*						3.2	4.4*	9.9
1.5	LC	2.1*	2.1*	9.2	11.9*	6.2	8.7*	4.6	6.8*	3.6	5.3*						3.1	4.3*	10.0
0	LC	2.8*	2.8*	8.9	9.9*	6.0	8.2*	4.5	6.3*	3.5	4.8*						3.2	3.8*	9.8
-1.5	LC			8.8	8.9*	5.9	7.0*	4.4	5.3*								3.6	3.8*	8.9
-3.0	LC																		

Height Can be slewed through 360° In longitudinal position of undercarriage Max. reach * Limited by hydr. capacity

The lift capacities on the stick end without attachment are stated in metric tons (t) and can be slewed through 360° on a firm, level supporting surface. Capacities are valid for 600 mm wide triple grouser pads. Indicated loads based on the ISO 10567 standard and do not exceed 75% of tipping or 87% of hydraulic capacity. The lift capacity of the unit is limited by its stability, the lifting capability of the hydraulic elements, or the maximum permissible lifting capacity of the load hook.

In accordance with the harmonised European Standard EN 474-5, hydraulic excavators used for lifting operations must be equipped with pipe fracture safety valves, an overload warning device, a load hook and a lift capacity chart.

LH 26 C – Equipment GA12

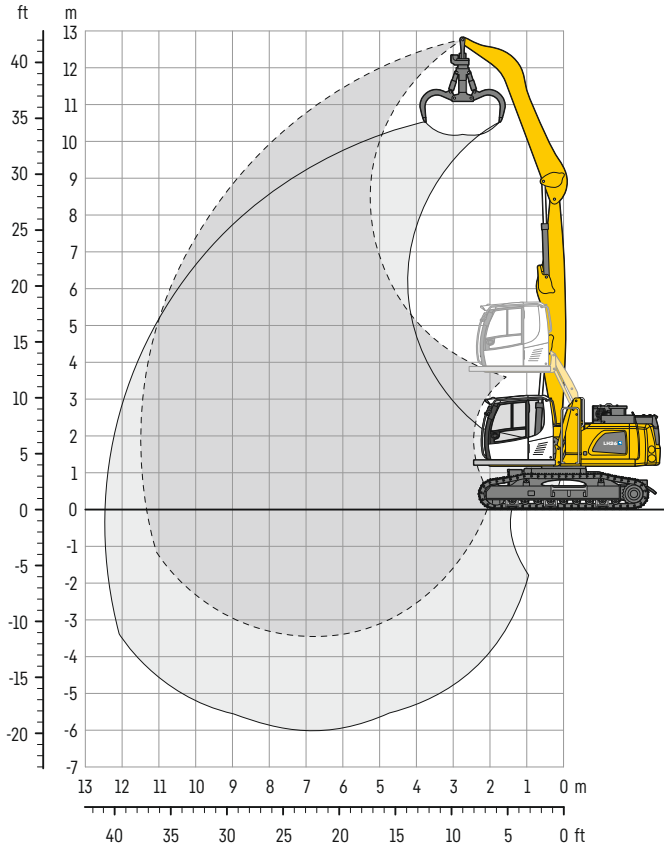

Dimensions

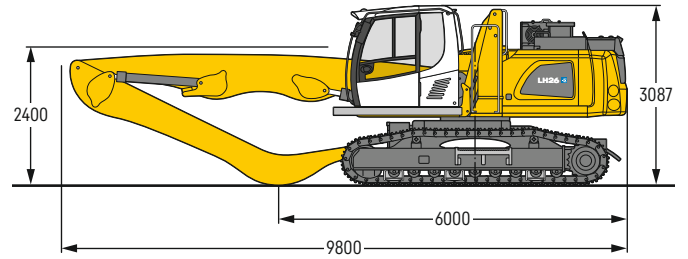

Operating weight and ground pressure

The operating weight includes the basic machine with hydr. cab elevation, straight boom 6.60 m, angled stick 5.00 m and multi-tine grab GM 65/0.60 m³ semi-closed tines.

Weight	28,500 kg
Pad width	600 mm
Ground pressure	on request

m	Undercarriage	3.0m		4.5m		6.0m		7.5m		9.0m		10.5m		12.0m		Max. reach		m	
		LC	LC	LC	LC	LC	LC	LC	LC	LC	LC	LC	LC	LC	LC	LC	LC		
12.0	LC			5.9*	5.9*												5.2*	5.2*	5.0
10.5	LC					5.9*	5.9*										4.1*	4.1*	7.4
9.0	LC					6.6*	6.6*	5.2	5.7*								3.7*	3.7*	8.9
7.5	LC					6.9*	6.9*	5.2	6.0*	3.9	5.2*						3.3	3.4*	9.9
6.0	LC					7.1*	7.1*	5.1	6.1*	3.8	5.3*	3.0	3.8*				2.9	3.3*	10.7
4.5	LC			8.9*	8.9*	6.9	7.6*	5.0	6.3*	3.8	5.4*	2.9	4.5				2.7	3.3*	11.2
3.0	LC	16.5*	16.5*	10.0	10.8*	6.6	8.1*	4.7	6.6*	3.6	5.4*	2.9	4.4				2.5	3.4*	11.4
1.5	LC	2.4*	2.4*	9.2	11.5*	6.2	8.4*	4.5	6.6*	3.5	5.4*	2.8	4.3*				2.5	3.5*	11.5
0	LC	2.2*	2.2*	8.2*	8.2*	5.9	8.3*	4.4	6.4*	3.4	5.1*	2.8	4.0*				2.5	3.2*	11.3
-1.5	LC	3.1*	3.1*	7.0*	7.0*	5.7	7.4*	4.2	5.8*	3.3	4.5*	2.7	3.2*				2.6	2.9*	10.8
-3.0	LC					5.6	6.0*	4.2	4.7*								3.4	3.5*	9.0

Height Can be slewed through 360° In longitudinal position of undercarriage Max. reach * Limited by hydr. capacity

The lift capacities on the stick end without attachment are stated in metric tons (t) and can be slewed through 360° on a firm, level supporting surface. Capacities are valid for 600 mm wide triple grouser pads. Indicated loads based on the ISO 10567 standard and do not exceed 75% of tipping or 87% of hydraulic capacity. The lift capacity of the unit is limited by its stability, the lifting capability of the hydraulic elements, or the maximum permissible lifting capacity of the load hook.

In accordance with the harmonised European Standard EN 474-5, hydraulic excavators used for lifting operations must be equipped with pipe fracture safety valves, an overload warning device, a load hook and a lift capacity chart.

LH 26 C – Equipment GK11

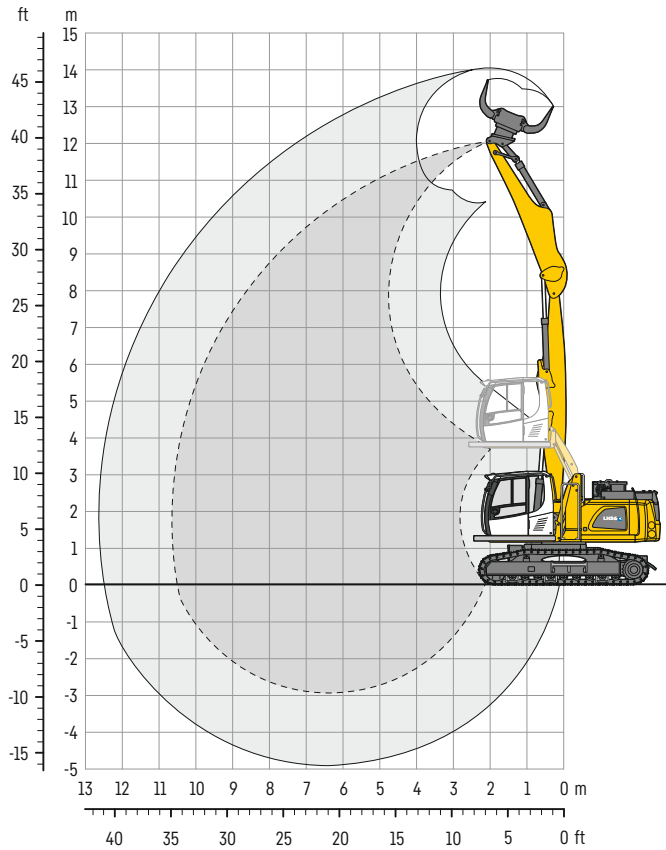

Dimensions

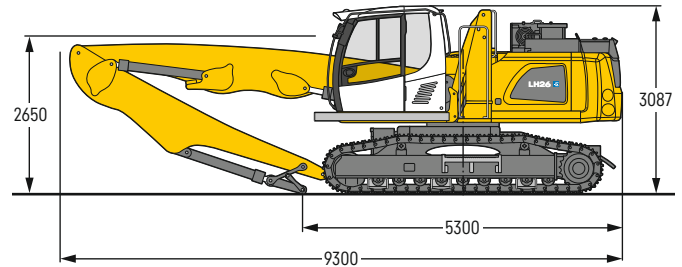

Operating weight and ground pressure

The operating weight includes the basic machine with hydr. cab elevation, straight boom 6.10 m, stick with tipping kinematics 4.50 m and sorting grab SG 25B / 0.55 m³ perforated shells.

Weight	28,600 kg
Pad width	600 mm
Ground pressure	on request

m	Undercarriage	3.0m		4.5m		6.0m		7.5m		9.0m		10.5m		12.0m		m		
12.0	LC															9.2*	9.2*	2.4
10.5	LC			7.3*	7.3*											5.1*	5.1*	6.0
9.0	LC					6.9*	6.9*	4.8	5.0*							4.2*	4.2*	7.8
7.5	LC					6.9*	6.9*	4.9	6.0*							3.5	3.8*	9.0
6.0	LC			7.6*	7.6*	6.9	7.1*	4.8	6.1*	3.5	5.2*					3.0	3.6*	9.8
4.5	LC			8.8*	8.8*	6.6	7.5*	4.7	6.2*	3.5	5.2*					2.7	3.5*	10.3
3.0	LC	16.4*	16.4*	9.8	10.7*	6.3	8.0*	4.5	6.4*	3.4	5.2*	2.6	4.0*			2.6	3.5*	10.6
1.5	LC	1.6*	1.6*	9.0	11.4*	5.9	8.2*	4.3	6.4*	3.3	5.0*	2.6	3.7*			2.5	3.4*	10.6
0	LC	1.8*	1.8*	8.5	9.7*	5.7	7.9*	4.1	6.1*	3.2	4.6*					2.6	2.9*	10.5
-1.5	LC			8.3	8.4*	5.5	7.0*	4.0	5.3*	3.2	3.8*					2.9	3.0*	9.7

Height Can be slewed through 360° In longitudinal position of undercarriage Max. reach * Limited by hydr. capacity

The lift capacities on the stick end without attachment are stated in metric tons (t) and can be slewed through 360° on a firm, level supporting surface. Capacities are valid for 600 mm wide triple grouser pads. Indicated loads based on the ISO 10567 standard and do not exceed 75% of tipping or 87% of hydraulic capacity. The lift capacity of the unit is limited by its stability, the lifting capability of the hydraulic elements, or the maximum permissible lifting capacity of the load hook.

In accordance with the harmonised European Standard EN 474-5, hydraulic excavators used for lifting operations must be equipped with pipe fracture safety valves, an overload warning device, a load hook and a lift capacity chart.

LH 26 P – Equipment GK11

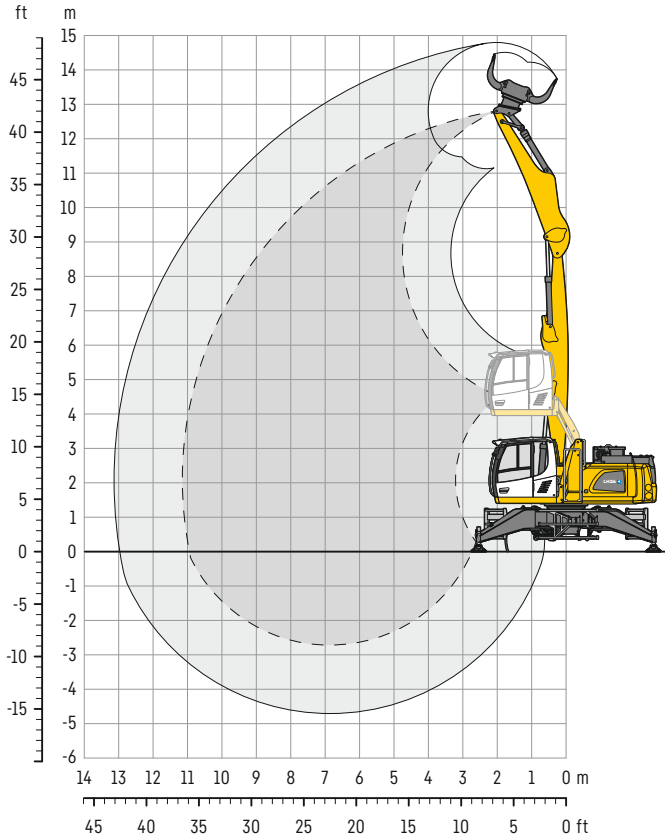

Dimensions

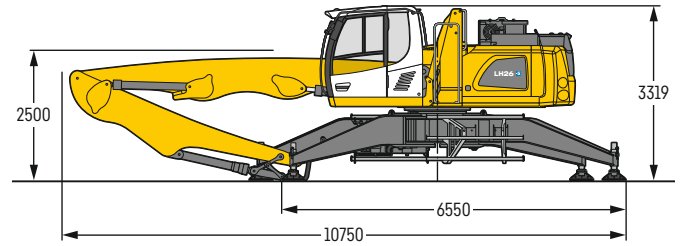

Operating weight

The operating weight includes the basic machine with hydr. cab elevation, straight boom 6.60 m, stick with tipping kinematics 4.50 m and sorting grab SG 25B / 0.55 m³ perforated shells.

Weight 23,500 kg

m	Undercarriage	3.0 m		4.5 m		6.0 m		7.5 m		9.0 m		10.5 m		12.0 m		m
12.0	Pedestal			6.6*	6.6*									6.0*	6.0*	4.8
10.5	Pedestal			7.6*	7.6*	6.5*	6.5*							4.5*	4.5*	7.2
9.0	Pedestal					6.9*	6.9*	5.9*	5.9*					3.9*	3.9*	8.7
7.5	Pedestal					6.9*	6.9*	5.9*	5.9*	5.1*	5.1*			3.7*	3.7*	9.7
6.0	Pedestal			7.9*	7.9*	7.2*	7.2*	6.0*	6.0*	5.1*	5.1*			3.5*	3.5*	10.4
4.5	Pedestal	7.5*	7.5*	10.0*	10.0*	7.6*	7.6*	6.2*	6.2*	5.1*	5.1*	4.2*	4.2*	3.5*	3.5*	10.9
3.0	Pedestal			11.0*	11.0*	8.0*	8.0*	6.3*	6.3*	5.1*	5.1*	4.0*	4.0*	3.5*	3.5*	11.1
1.5	Pedestal			8.5*	8.5*	8.1*	8.1*	6.2*	6.2*	4.9*	4.9*	3.8*	3.8*	3.1*	3.1*	11.1
0	Pedestal	1.1*	1.1*	5.6*	5.6*	7.5*	7.5*	5.8*	5.8*	4.5*	4.5*	3.2*	3.2*	2.6*	2.6*	10.9
-1.5	Pedestal			6.1*	6.1*	6.4*	6.4*	5.0*	5.0*	3.7*	3.7*			2.8*	2.8*	9.9

Height Can be slewed through 360° In longitudinal position of undercarriage Max. reach * Limited by hydr. capacity

The lift capacities on the stick end without attachment are stated in metric tons (t) and can be slewed through 360° on a firm, level supporting surface. Indicated loads based on the ISO 10567 standard and do not exceed 75% of tipping or 87% of hydraulic capacity. The lift capacity of the unit is limited by its stability, the lifting capability of the hydraulic elements, or the maximum permissible lifting capacity of the load hook.

In accordance with the harmonised European Standard EN 474-5, hydraulic excavators used for lifting operations must be equipped with pipe fracture safety valves, an overload warning device, a load hook and a lift capacity chart.

LH 26 P – Equipment GA13

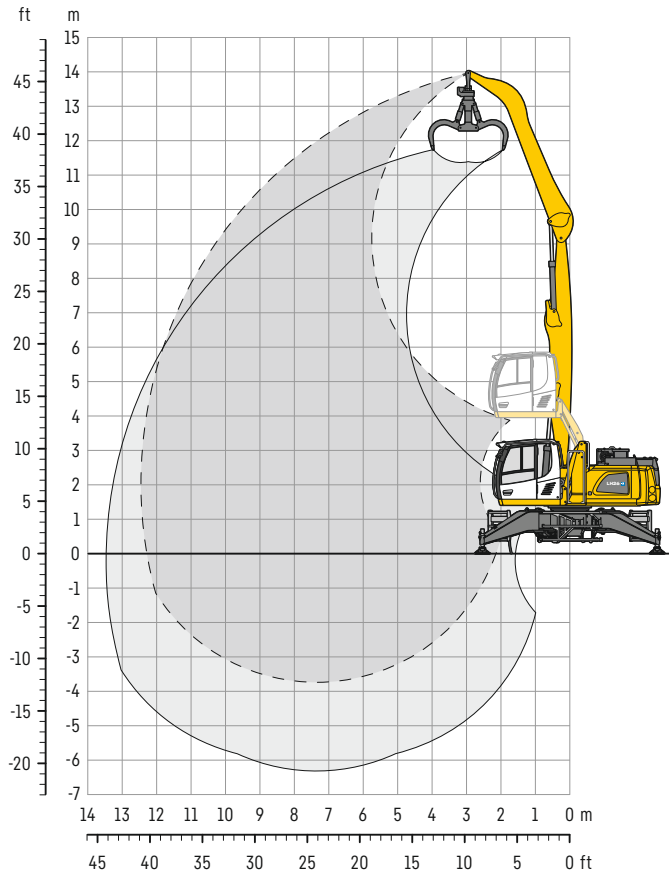

Dimensions

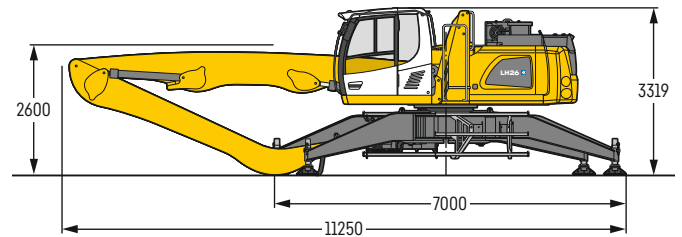

Operating weight

The operating weight includes the basic machine with hydr. cab elevation, straight boom 7.10 m, angled stick 5.50 m and multi-tine grab GM 65 / 0.60 m³ semi-closed tines.

Weight	23,600 kg
--------	-----------

m	Undercarriage	3.0m		4.5m		6.0m		7.5m		9.0m		10.5m		12.0m		Max. reach		m
		360°	360°	360°	360°	360°	360°	360°	360°	360°	360°	360°	360°	360°	360°	360°	360°	
13.5	Pedestal			5.4*	5.4*											5.2*	5.2*	4.6
12.0	Pedestal					5.4*	5.4*									3.9*	3.9*	7.4
10.5	Pedestal					6.0*	6.0*	5.3*	5.3*	3.6*	3.6*					3.4*	3.4*	9.1
9.0	Pedestal					6.3*	6.3*	5.7*	5.7*	5.0*	5.0*					3.2*	3.2*	10.3
7.5	Pedestal					6.6*	6.6*	5.7*	5.7*	5.1*	5.1*	4.3*	4.3*			3.0*	3.0*	11.2
6.0	Pedestal					7.0*	7.0*	5.9*	5.9*	5.1*	5.1*	4.5*	4.5*			3.0*	3.0*	11.8
4.5	Pedestal			8.4*	8.4*	7.5*	7.5*	6.2*	6.2*	5.2*	5.2*	4.5*	4.5*	3.6*	3.6*	3.0*	3.0*	12.2
3.0	Pedestal	16.6*	16.6*	10.7*	10.7*	8.0*	8.0*	6.4*	6.4*	5.3*	5.3*	4.4*	4.4*	3.6*	3.6*	3.0*	3.0*	12.4
1.5	Pedestal	1.5*	1.5*	11.3*	11.3*	8.2*	8.2*	6.4*	6.4*	5.2*	5.2*	4.3*	4.3*	3.4*	3.4*	3.0*	3.0*	12.4
0	Pedestal	1.8*	1.8*	5.7*	5.7*	8.0*	8.0*	6.2*	6.2*	5.0*	5.0*	4.0*	4.0*	3.0*	3.0*	2.7*	2.7*	12.3
-1.5	Pedestal	2.6*	2.6*	5.4*	5.4*	7.2*	7.2*	5.7*	5.7*	4.5*	4.5*	3.5*	3.5*			2.5*	2.5*	11.8
-3.0	Pedestal					5.8*	5.8*	4.7*	4.7*	3.7*	3.7*					2.9*	2.9*	10.0

Height Can be slewed through 360° In longitudinal position of undercarriage Max. reach * Limited by hydr. capacity

The lift capacities on the stick end without attachment are stated in metric tons (t) and can be slewed through 360° on a firm, level supporting surface. Indicated loads based on the ISO 10567 standard and do not exceed 75% of tipping or 87% of hydraulic capacity. The lift capacity of the unit is limited by its stability, the lifting capability of the hydraulic elements, or the maximum permissible lifting capacity of the load hook.

In accordance with the harmonised European Standard EN 474-5, hydraulic excavators used for lifting operations must be equipped with pipe fracture safety valves, an overload warning device, a load hook and a lift capacity chart.

Machine stabilities sorting grabs

LH 26 M – Max. material weight in t/m³

Grab	Shell type	Capacity m ³	Mounting for direct mounting		Mounting for quick coupler SWA 48	
			GK11	VK9	GK11	VK9
SG 20B	perforated	0.40	3.5	2.2	2.8	1.5
SG 20B	perforated	0.50	2.7	1.7	2.1	1.1
SG 20B	perforated	0.60	2.1	1.3	1.7	0.8
SG 20B	perforated	0.70	1.8	1.0	1.4	0.7
SG 20B	closed	0.40	3.4	2.2	2.7	1.5
SG 20B	closed	0.50	2.6	1.6	2.1	1.1
SG 20B	closed	0.60	2.1	1.3	1.7	0.8
SG 20B	closed	0.70	1.7	1.0	1.4	0.6
SG 25B	perforated	0.55	2.0	1.1	1.5	0.6
SG 25B	perforated	0.75	1.3	0.7	1.0	0.3
SG 25B	perforated	0.90	1.0	0.5	0.7	0.2
SG 25B	perforated	1.10	0.8	0.3	0.5	-
SG 25B	ribbed	0.50	2.1	1.1	1.5	0.5
SG 25B	ribbed	0.65	1.5	0.7	1.0	0.3
SG 25B	ribbed	0.80	1.1	0.4	0.7	-
SG 25B	closed	0.55	1.9	1.0	1.4	0.5
SG 25B	closed	0.75	1.3	0.6	0.9	0.3
SG 25B	closed	0.90	1.0	0.5	0.7	-
SG 25B	closed	1.10	0.8	0.3	0.5	-

- = Load values at maximum outreach insufficient

LH 26 C – Max. material weight in t/m³

Grab	Shell type	Capacity m ³	Mounting for direct mounting	Mounting for quick coupler SWA 48
			GK11	GK11
SG 20B	perforated	0.40	1.5	0.8
SG 20B	perforated	0.50	1.1	0.5
SG 20B	perforated	0.60	0.8	0.3
SG 20B	perforated	0.70	0.6	0.2
SG 20B	closed	0.40	1.4	0.7
SG 20B	closed	0.50	1.0	0.5
SG 20B	closed	0.60	0.8	0.3
SG 20B	closed	0.70	0.6	0.2
SG 25B	perforated	0.55	0.5	-
SG 25B	perforated	0.75	0.3	-
SG 25B	perforated	0.90	0.2	-
SG 25B	perforated	1.10	-	-
SG 25B	ribbed	0.50	0.5	-
SG 25B	ribbed	0.65	0.2	-
SG 25B	ribbed	0.80	-	-
SG 25B	closed	0.55	0.5	-
SG 25B	closed	0.75	0.2	-
SG 25B	closed	0.90	-	-
SG 25B	closed	1.10	-	-

- = Load values at maximum outreach insufficient

Machine stabilities sorting grabs

LH 26 P – Max. material weight in t/m³

Grab	Shell type	Capacity m ³	Mounting for direct mounting		Mounting for quick coupler SWA 48	
			GK11		GK11	
SG 20B	perforated	0.40		3.5		2.8
SG 20B	perforated	0.50		2.7		2.1
SG 20B	perforated	0.60		2.1		1.7
SG 20B	perforated	0.70		1.8		1.4
SG 20B	closed	0.40		3.4		2.7
SG 20B	closed	0.50		2.6		2.1
SG 20B	closed	0.60		2.1		1.7
SG 20B	closed	0.70		1.7		1.4
SG 25B	perforated	0.55		2.0		1.5
SG 25B	perforated	0.75		1.3		1.0
SG 25B	perforated	0.90		1.0		0.7
SG 25B	perforated	1.10		0.8		0.5
SG 25B	ribbed	0.50		2.1		1.5
SG 25B	ribbed	0.65		1.5		1.0
SG 25B	ribbed	0.80		1.1		0.7
SG 25B	closed	0.55		1.9		1.4
SG 25B	closed	0.75		1.3		0.9
SG 25B	closed	0.90		1.0		0.7
SG 25B	closed	1.10		0.8		0.5

- = Load values at maximum outreach insufficient

Attachments

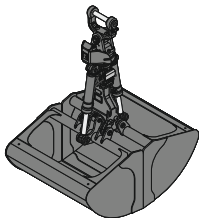

Grab for loose material

Shells for loose material with cutting edge (without teeth)

Grab model GMZ 26			
Width of shells	mm	1,250	1,500
Capacity	m ³	1.50	1.80
Weight	kg	1,170	1,255

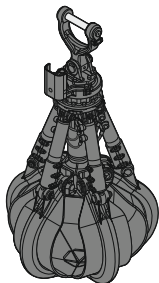

Multi-tine grab

		open		semi-closed		closed	
Grab model GM 64 (4 tines)							
Capacity	m ³	0.40	0.60	0.40	0.60	0.40	0.60
Weight	kg	800	910	940	1,060	1,100	1,265
Grab model GM 65 (5 tines)							
Capacity	m ³	0.40	0.60	0.40	0.60	0.40	0.60
Weight	kg	1,175	1,310	1,350	1,490	1,365	1,605

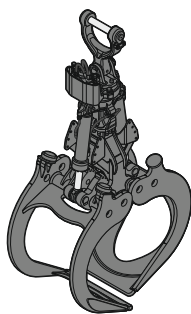

Wood grab

Grab model GM 10B round-shaped (complete overlapping, vertical cylinders)				
Size	m ²	0.80	1.00	1.30
Cutting width	mm	810	810	810
Height of grab, closed	mm	2,124	2,249	2,375
Weight	kg	1,260	1,305	1,360

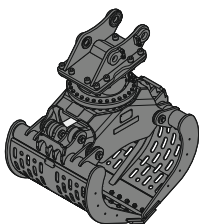

Sorting grab

		per-forated			ribbed			closed			per-forated	
Grab model SG 25B												
Width of shells	mm	800	800	800	1,000	1,000	1,000	1,200	1,200	1,200	1,400	1,400
Capacity	m ³	0.55	0.50	0.55	0.75	0.65	0.75	0.90	0.80	0.90	1.10	1.10
Max. closing force	kN	60	60	60	60	60	60	60	60	60	60	60
Weight incl. quick coupler mounting SWA 48	kg	1,240	1,285	1,260	1,305	1,370	1,330	1,370	1,455	1,400	1,435	1,470



Load hook

Max. load	t	12.5
Height with suspension	mm	930
Weight	kg	135

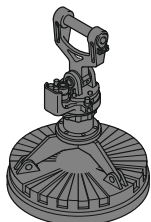

Magnet devices / lifting magnets

Generator	kW	10
Electromagnet with suspension		
Power	kW	5.5
Diameter of magnet	mm	1,150
Weight	kg	1,125*

* only magnet plate

Equipment

Undercarriage

	26 M	26 C	26 P
Track pads, variants		+	
Individual levelling outriggers			•
Individual control outriggers	+		
Shuttle axle lock, automatic	•		
Outrigger monitoring system	+		
Tyres, variants	+		
Trailing cable	•	•	•
Protection for piston rods, outriggers	+		
Two storage compartments	•		
Cable reel system	+	+	

Upper carriage

	26 M	26 C	26 P
Upper carriage right side light, 1 piece, LED	•	•	•
Upper carriage rear light, 2 pieces, LED	+	+	+
Generator	+	+	+
Main battery switch for electrical system	•	•	•
Mobility Kit	+	+	
Recycling package	•	•	•
Amber beacon, at upper carriage, LED double flash	+	+	+
Protection for headlights	+	+	+
Protection for rear lights	+	+	+
Tool equipment, extended	+	+	+

Hydraulic system

	26 M	26 C	26 P
Electronic pump regulation	•	•	•
Liebherr hydraulic oil from -20 °C to +40 °C	•	•	•
Liebherr hydraulic oil, biologically degradable	•	+	+
Magnetic rod in hydraulic tank	+	•	•
Bypass filter	+	+	+
Preheating hydraulic oil	+	+	+

Engine

	26 M	26 C	26 P
Automatic engine shut-down (time adjustable)	+	+	+
Preheating coolant*	+	+	+

Cooling system

	26 M	26 C	26 P
Radiator, large-mesh, for dust-intensive operation	•	•	•
Reversible fan drive	•	•	•
Protective grid (close-mesh) in front of cooler intake, extendible	•	•	•



Cab

	26 M	26 C	26 P
Stabilizer, control lever, left console	+		
Stabilizer, proportional control on left joystick	●		
Cab lights front, halogen	+	+	+
Cab lights front, halogen (under rain cover)	●	●	●
Cab lights front, LED	+	+	+
Cab lights front, LED (under rain cover)	+	+	+
Armrest adjustable	●	●	●
Slewing gear brake Comfort, button on the left or right joystick	+	+	+
Operator's seat Comfort	●	●	●
Operator's seat Premium	+	+	+
Driving alarm			
(acoustic signal is emitted during travel, can be switched ON / OFF)	+	+	
Fire extinguisher	+	+	+
Footrest	+	+	+
Horn, button on left joystick	●	●	●
Joystick steering (max. 12 km/h)	●		
Joystick and wheel steering (slim version)	+		
Cab elevation, hydraulic (LHC)	●	●	●
Cab elevation, hydraulic with tilt function (LHC)	+	+	+
Cab elevation, rigid (LFC)	+	+	+
Wheel steering (slim version)	+		
LiDAT, vehicle fleet management	●	●	●
Engine shut-down (emergency stop) cab	●	●	●
Proportional control	●	●	●
Radio Comfort, control via display with handsfree set	+	+	+
Preparation for radio installation	●	●	●
Back-up alarm			
(acoustic signal is emitted traveling backward, can not be switched off)	+		
Amber beacon, on cab, LED double flash	+	+	+
Windows made from impact-resistant laminated safety glass	+	+	+
Windscreen wiper, roof	+	+	+
Windshield wiper, entire windscreen	●	●	●
FOPS top guard	+	+	+
FGPS front guard, tiltable	+	+	+
Sun visor	+	+	+
Stationary air-conditioning	●	●	●
Left control console, folding	●	●	●



Equipment

	26 M	26 C	26 P
Boom lights, 2 pieces, halogen	●	●	●
Boom lights, 2 pieces, LED	+	+	+
Stick lights, 2 pieces, halogen	●	●	●
Stick lights, 2 pieces, LED	+	+	+
Filter system for attachment	+	+	+
Height limitation and stick shutoff, electronically	+	+	+
Boom cylinder cushioning	+	+	+
Stick camera (with separate monitor), bottom side, with protection	+	+	+
Load holding valve tipping cylinder	+	+	+
Liebherr multi coupling system	+	+	+
Liebherr quick coupler, hydraulic	+	+	+
Pipe fracture safety valves hoist cylinders	●	●	●
Pipe fracture safety valves stick cylinders	●	●	●
Quick coupling system Solidlink	+	+	+
Quick coupling system MH 40B	+	+	+
Protection for piston rod, tipping cylinder	+	+	+
Protection for piston rods, hoist cylinder	+	+	+
Protection for piston rods, stick cylinder	+	+	+
Overload warning device	+	+	+



Complete machine

	26 M	26 C	26 P
Packages			
Recycling package	●	●	●
Lubrication			
Lubrication undercarriage, manually - decentralised (grease points)	●		
Lubrication undercarriage, manually - centralised (one grease point)	+		
Central lubrication system for uppercarriage and equipment, automatically	●	●	●
Central lubrication system for undercarriage, automatically	+		
Centralised lubrication extended for attachment	+	+	+
Special coating			
Pipal coating, variants	+	+	+
Monitoring			
Rear view monitoring with camera	●	●	●
Side view monitoring with camera	●	●	●

● = Standard, + = Option

* = country-dependent

Options and /or special equipment, supplied by vendors other than Liebherr, are only to be installed with the knowledge and approval of Liebherr in order to retain warranty.

The Liebherr Group



Global and independent: more than 70 years of success

Liebherr was founded in 1949 when, with the development of the world's first mobile tower crane, Hans Liebherr laid the foundations for a family business now employing nearly 51,000 people and comprising over 140 companies across every continent.

The parent company is Liebherr-International AG in Bulle, Switzerland, whose associates are exclusively members of the Liebherr family.

Leaders and pioneers

Liebherr is a pioneer and its forward-looking approach has seen it make important contributions to technology history over a wide variety of industries. Employees throughout the world continue to share the courage of the founder, sharing a passion to produce innovative products and a determination to provide world-leading equipment and machinery.

Diversified portfolio

The company is one of the world's biggest construction equipment manufacturers and provides high-quality, user-oriented products and services to sectors including: earthmoving, material handling, deep foundations, mining, mobile and crawler cranes, tower cranes, concrete production and distribution, maritime cranes, aerospace and transportation, gear technology and automation, refrigeration and freezing, components and hotels.

Customised care

Liebherr solutions are characterised by precision, implementation and longevity. The company is committed to technological excellence and to providing customers with solutions that match their needs exactly. That customer focus does not end with delivery of a product but continues through a comprehensive range of back-up and support services.

www.liebherr.com

Liebherr-Hydraulikbagger GmbH

Liebherrstraße 12 • 88457 Kirchdorf/Iller, Germany • Phone +49 7354 80-0 • Fax +49 7354 80-72 94
info.lhb@liebherr.com • www.liebherr.com • www.facebook.com/LiebherrConstruction