R 9150

Generation 7

LIEBHERR

Mining excavator



Technologies

- Assistance systems
- Liebherr power efficiency
- Bucket filling assistant

Powertrain options

- Liebherr: 565 kW (FCO, Tier 4f)
757 HP
- Electric: 565 kW (50 Hz, 60 Hz)
757 HP

Backhoe configuration

- Overall weight: 130 tonnes
143 tons
- Bucket payload: 16 tonnes
18 tons

Face shovel configuration

- Overall weight: 130 tonnes
143 tons
- Bucket payload: 15 tonnes
17 tons

Overview

R 9150



Diesel drive 565 kW / 757 HP
Electric drive 565 kW / 757 HP



BH 8.8 – 9.6 m³ / 11.5 – 12.6 yd³
FS 8.3 m³ / 10.9 yd³



BH 130 tonnes / 143 tons
FS 130 tonnes / 143 tons

High performance execution

Sustainable & efficient performance

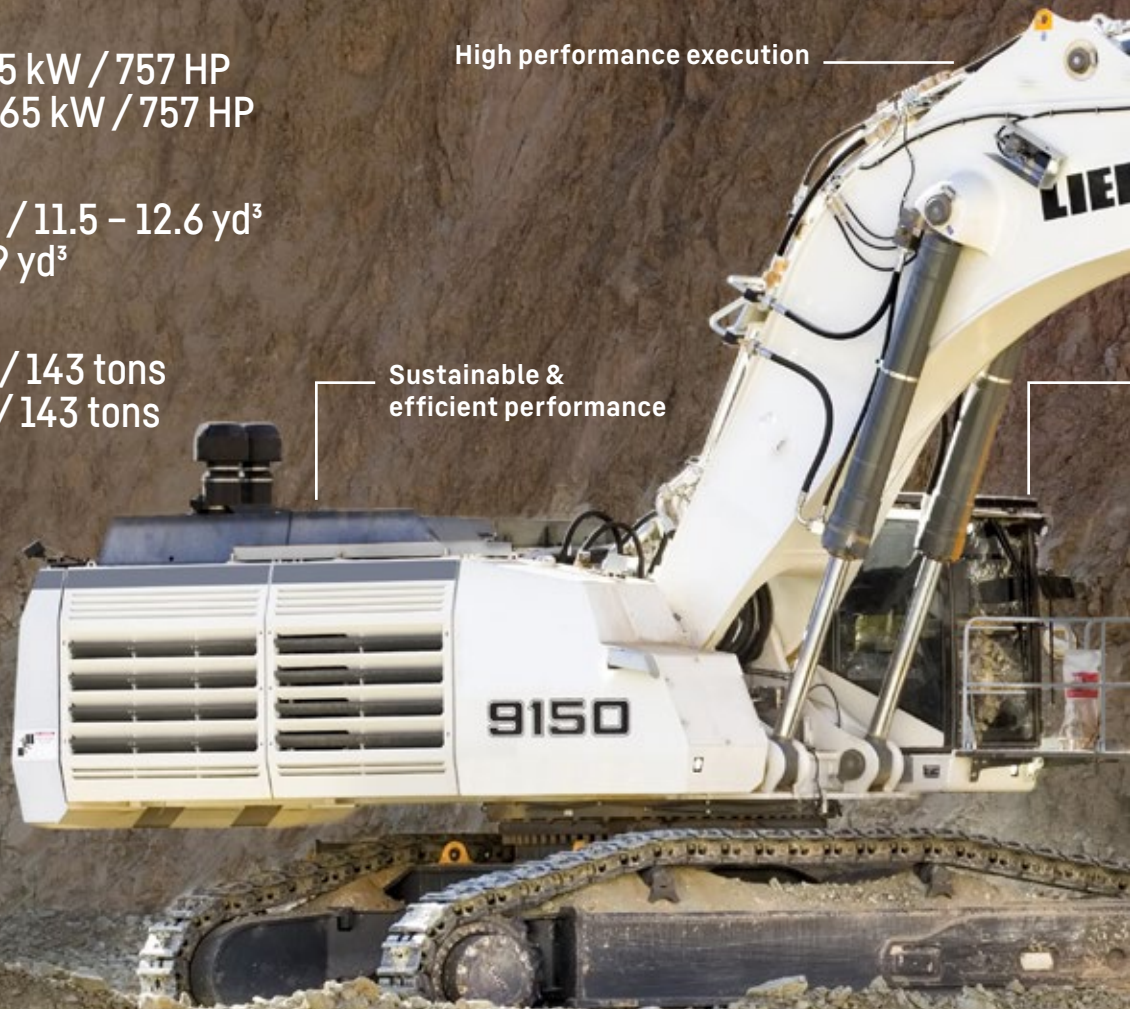

Stress-relieved structure

The R 9150 attachment has been designed with long boom radius and limited number of sharp edges to optimize the stress applied on the component. Reduced weight of attachment to guarantee faster cycle time and increased payload.

Standard heavy-duty bucket

- Highest bucket capacity in its class with proven EVO bucket design
- Maximised payload with versatile Liebherr bucket solution
- Shift levers and bucket links with integrated greasing system

Perfect shovel truck match

- 3 pass loading of 55 tonne trucks
- 4 pass loading of 65 tonne trucks
- 6 pass loading of 90-100 tonne trucks



Patented EVO bucket

Latest cutting-edge technologies

Latest cabin generation

- Increased comfort and ergonomics
- User-friendly operator station
- Suspended operator seat
- Slim line dash and LED lighting

Latest cutting-edge technologies

- Liebherr assistance systems
- Advanced machine monitoring with modern 15" touchscreens (day & night mode)
- Permanent vision system

Sustainable performance

- US EPA Tier 4f / EU Stage V compliant engine
- SCR after-treatment technology
- Serial implementation Liebherr power efficiency solutions
- Electric drive version

Performance & sustainability

Powertrain



+25 %

Fuel efficiency



Diesel drive

Liebherr D9512

565 kW / 757 HP at 1,800 RPM
12 cylinder V-engine
Displacement 24.24 l / 1,479 in³

US EPA Tier 4f / EU Stage V

Using selective catalytic reduction technology to comply with latest emission regulations the R 9150 combines flexibility to meet customer expectations without compromising productivity.

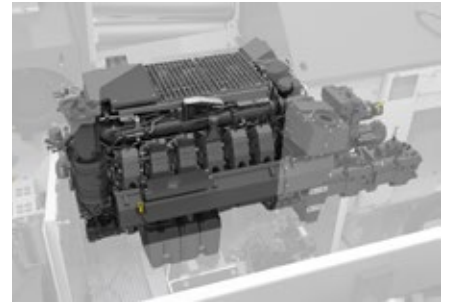

Electric drive

Liebherr offers an alternative to diesel engines allowing customers to balance performance with environmental consciousness. Building on 30 years' experience in electric drive excavators, the electric drive option allows lower maintenance costs and reduced noise pollution. With high motor efficiency, the electric drive gives maximum performance.

- Lower maintenance costs
- 6,000 V (other voltage on request)
- Integrated design elements on all machine structures
- Optional cable reeler

No exhaust emission

Liebherr electric R 9150 provides class leading cycle times using electric motors without exposing people and the environment to diesel exhaust emissions. Complying with all Non Road Mobile Machinery (NRMM) emission regulations, the R 9150 E can be operated all around the world.

Less noise level

Liebherr Electric driven machines can be operated without restrictions in noise sensitive areas.



Productivity

Attachment

Build for maximum productivity

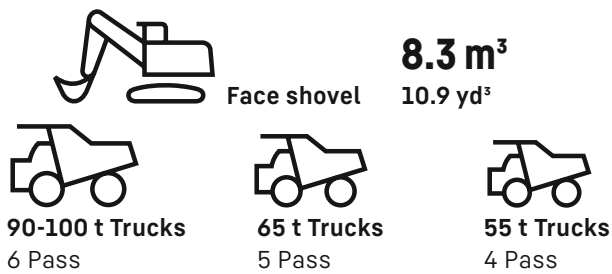
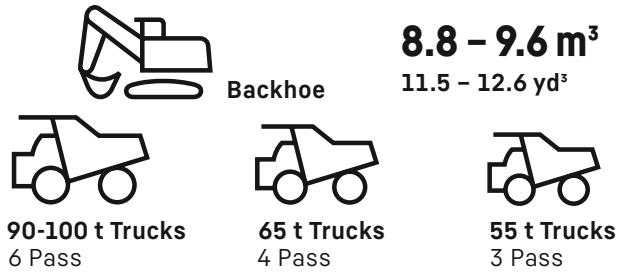

Maximised payload

Designed for best force distribution, the attachment design delivers high digging and hoisting forces, which ensures maximum payload during each cycle. The EVO bucket allows the operator to take advantage of each pass and therefore increase productivity.

Optimised cost per tonne

Built to outperform all competitors in its class, the R 9150 is a perfect loader for 55 t up to 100 t off-highway trucks and offers a wide array of uses.

*Liebherr EVO bucket compared to competitor's average bucket capacity.



+8%
Loading capacity*



Automation

Bucket filling assistant

The first automation product of the Liebherr hydraulic excavator portfolio allows easier bucket filling and consistent bucket fill factors, especially in blocky or hard digging conditions. As a result overall productivity improves while operator's fatigue decreases.



Anti-stalling function

Prevents the bucket from being stalled during the digging phase.



Semi-automatic bucket filling function

Allows the machine electronic to realise fully automatic attachment movements.



Discover more.

Comfort Operator cabin

Enhanced comfort & ergonomics



Advanced machine monitoring

- Modern and large touchscreens
- State-of-the-art on-board technologies
- Long term data storage for maintenance
- User-friendly piloting station
- On-board diagnostics to service staff



Superior comfort

- Tinted laminated safety glass
- Armored front window
- Adjustable air suspended seat
- A/C with dust filter in fresh/ recirculated air

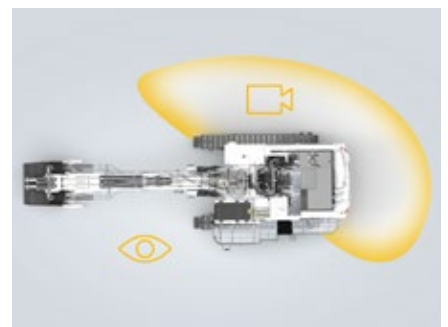

Vision system

The R 9150 offers superior visibility of the machine's surroundings. The dedicated monitor inside the cabin provides continuous rear and side vision around the machine, from the two cameras strategically fixed on the uppercarriage.



Working environment

Operator comfort

Resiliently mounted, the modern large cab design reduces vibrations and limits noise to provide a comfortable workspace. Providing ideal working conditions and optimal visibility on attachment, the cab can be optioned with a comfort kit and a pre-heating system for the most demanding conditions.

Optional

- Cab pressurization
- FOPS top guard
- Premium heated seats
- Four point harness
- HEPA filtration system
- Front protective grid



Assistance systems

The best performance. Easy.

Get the best out of your Liebherr mining excavator

Available today on the R 9150, the Liebherr assistance systems are advanced onboard applications designed to support operators to become more efficient through analytics and actionable insights. Systems will assist the operator to obtain optimal productivity and efficiency by providing realtime operational information.



Want to live the real experience?



Measure and analyse every bucket payload for optimal truck loading



Data visualised within different views & advanced filtering



Display targeted productivity and actual payload with 99% accuracy



Provide transparency of performance, operating time and fuel efficiency



Identify operational conformance and improve operator effectiveness



State-of-the-art on-board touchscreen displays



Make informed decisions



Increase productivity

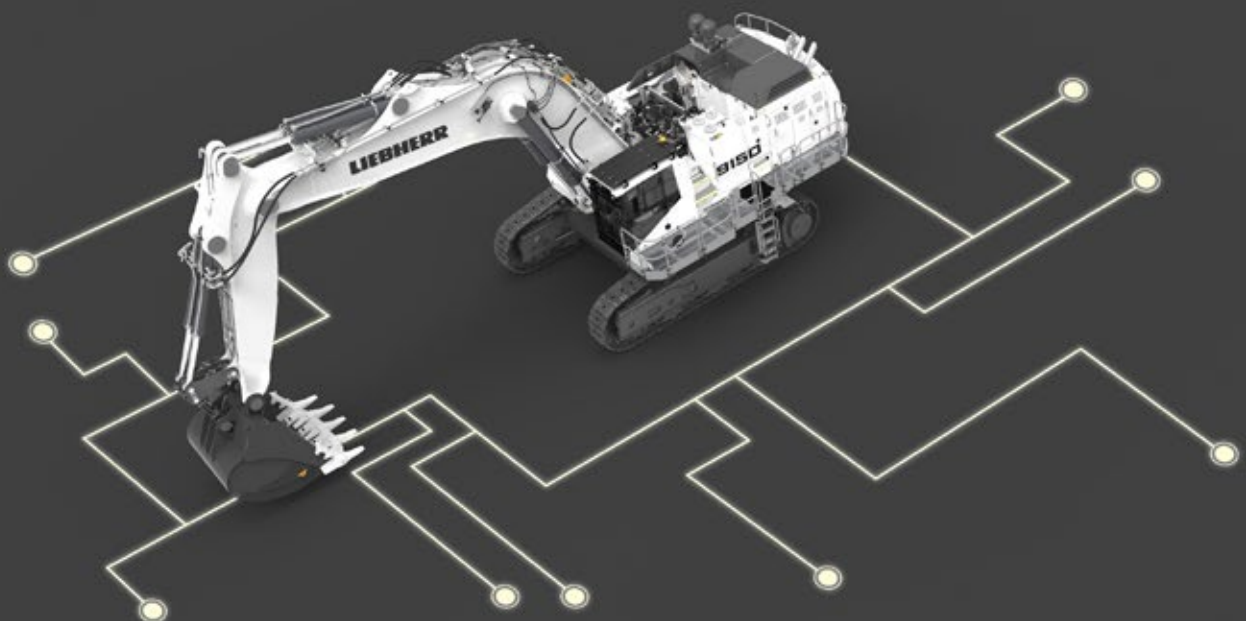



Truck loading assistant

Assists the operator to obtain target truck payloads.

With 99% measurement accuracy

- Measures instantaneously the bucket payload
- Provides real-time information to the operator
- Strategises the number of passes required
- Computes the best truck loading strategy
- Automatic truck recognition (optional)



Performance monitoring

Measures and analyses the overall performance.

Using KPIs, histograms and time-related charts

- Production KPIs
- Loading indicators
- Time distribution
- Energy efficiency



Application severity

Quantifies application, reports severity indicators and provides an overall application severity score.

KPIs to indicate and display the application as sensed by the machine

- Underfoot and digging conditions
- Abrasiveness and travel ratio
- Engine load factor and temperature variation
- Machine inclination, loading, etc.



Operational conformance

Detects and counts events to improve operator effectiveness.

Several filtering criteria to identify specific events

- Swinging into digging face
- Digging with swing brake activated
- Turning the machine with the attachment
- Bucket hitting track pads, etc.

Performance

Advanced hydraulic system

Highest
digging force

530 kN

Breakout force

620 kN

in its class



Fast & precise movement

Intelligent power management system

The Liebherr R 9150 mining excavator is equipped with a closed loop swing circuit. Kinetic energy is recovered when the swing motion is used during deceleration to drive the main and auxiliary pumps resulting in fuel consumption reduction.



Cylinder dampening through IMUs provides smoother attachment movements without affecting attachment speed.

Independent cooling system

Oil and water cooling fans are independently and electronically managed. The oversized cooling systems reduce parasitic demand on engine horsepower ensuring maximum available horsepower is provided to the excavator working circuits.

Valve bank control system

- Under slung arch hoses to improve lifetime
- Flow optimized hose fittings
- Less hydraulic pressure losses by design
- Pilot valves integrated into valve blocks



Moving more with less

Patented Liebherr power efficiency

Specific engine and hydraulic management, drastically reducing fuel consumption without any compromise on machine productivity.

- Adapted piloting processes according to operator requirements and machine condition
- Electronically controlled pressure and oil flow
- Reduce hydraulic throttling and load profile of the engine for increased component lifetime

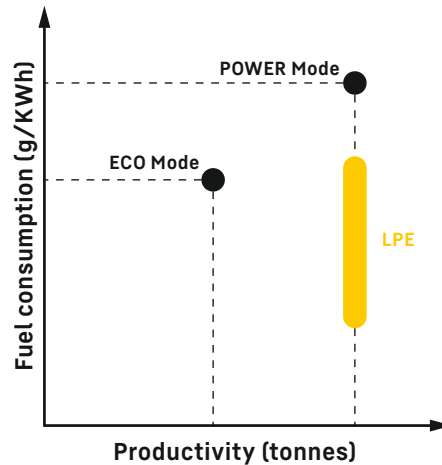

- Previous R 9150B/R 9150 G6
- R 9150 G7

Up to **20 %**
less fuel consumption

"Adapt the power and the hydraulic flow specifically to the load profile."

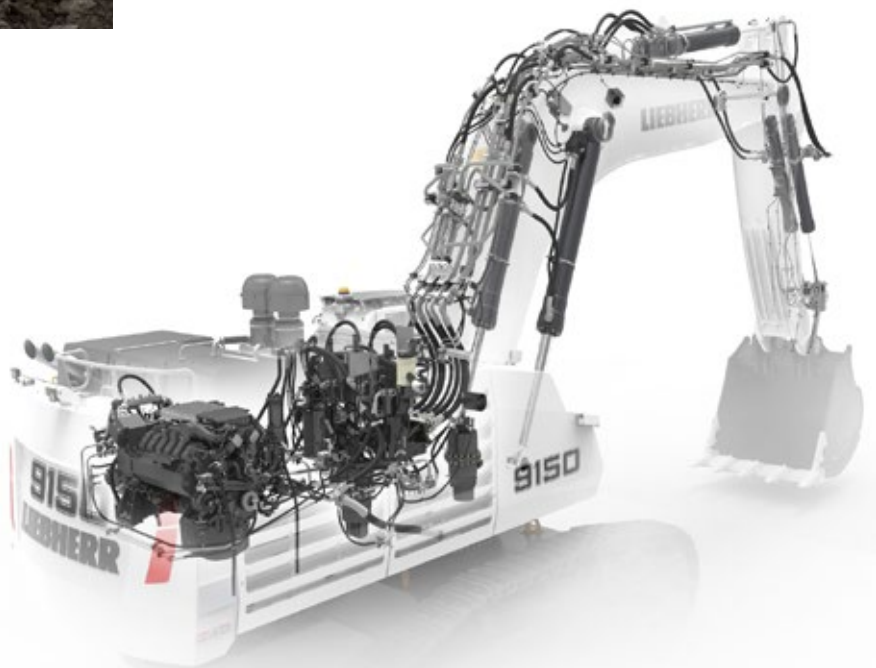

Safety

Protecting your most important asset



Machine accessibility

The R 9150 can be fitted with an ergonomic hydraulically controlled 45 degree stairway with handrails, providing safe access to the upper-carriage. Single side access to all service points.

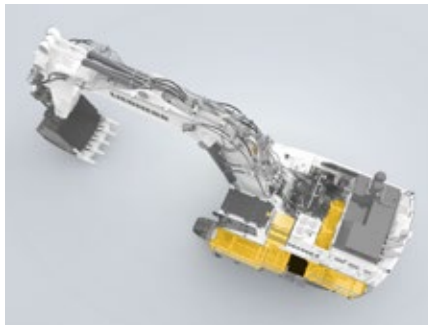

Wide catwalks for inspection

Enlarged walkways allow easy and safe access for inspection and maintenance around engine, fans, and pumps. All routine service items have been located to allow effortless inspection and replacement.



Emergency stops and emergency exits

Emergency stops are specifically located throughout the machine, increasing safety. A emergency drop-down ladder guarantees safe and quick exit from the machine.



Advanced engine fire protection

After treatment systems and turbochargers are heat shielded. The engines are mechanically segregated from hydraulic components, further improving on machine safety.



LED lighting system

Thanks to LED long-reach lights located on attachment, upper-carriage and counterweight, the machine offers best visibility to the operator and to the people/equipment around.



Safe surrounding area

Horn, LED working lights, LED service lights, LED access lights, flashing lights and travel alarm guarantee safe 24 / 7 operation and maintenance conditions.

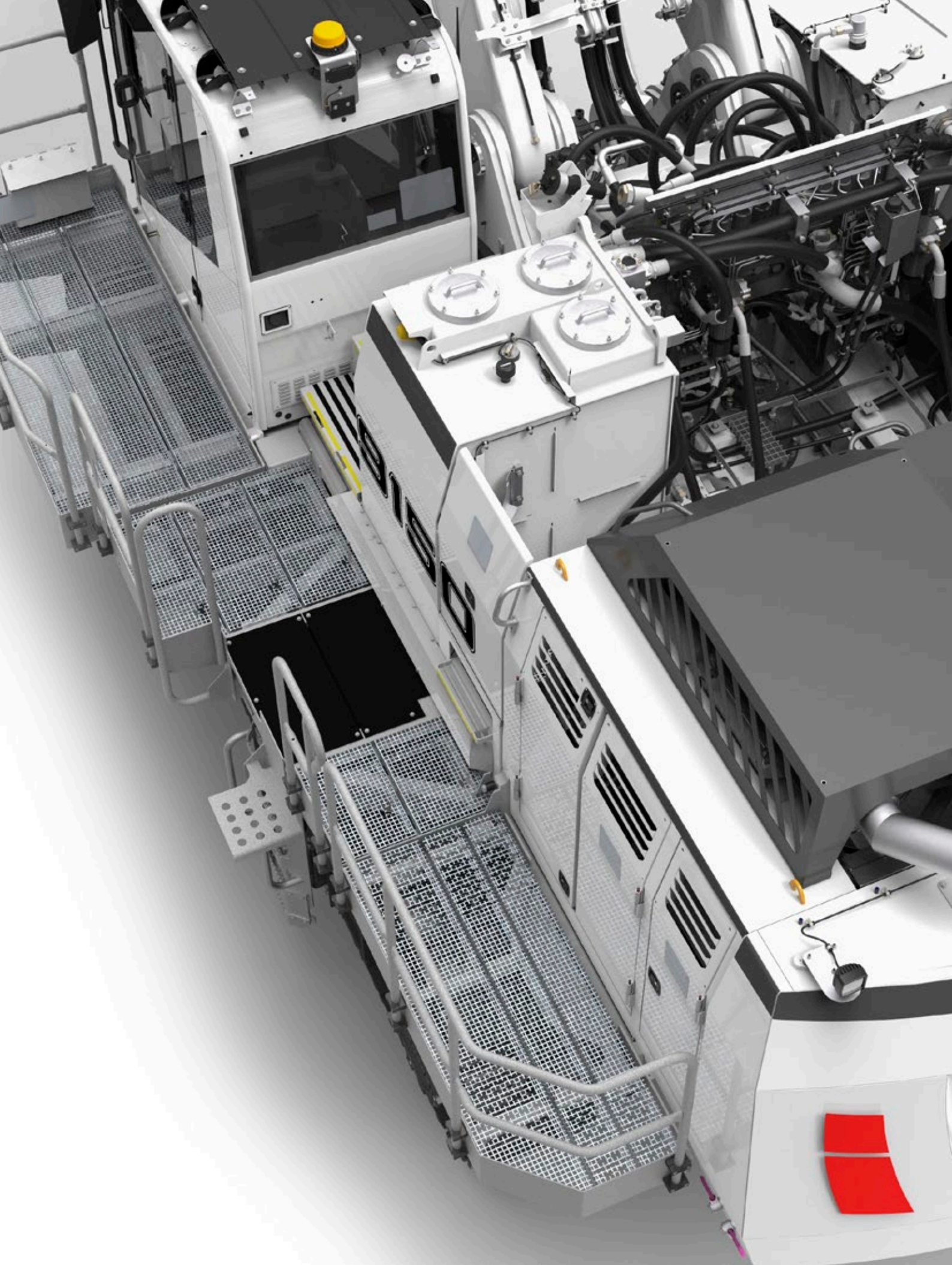

Maintenance

Easy & safe operations

24/7
Operations



Centralised service

Uppercarriage of the R 9150 has been designed for easier maintenance and quicker servicing. The central service area provides accessibility to uppercarriage fluid compartments reducing machine downtime. Refill and drain points of the

R 9150 are easily accessed from the upperstructure or directly from the ground with optional fast couplings and depressurized valves.

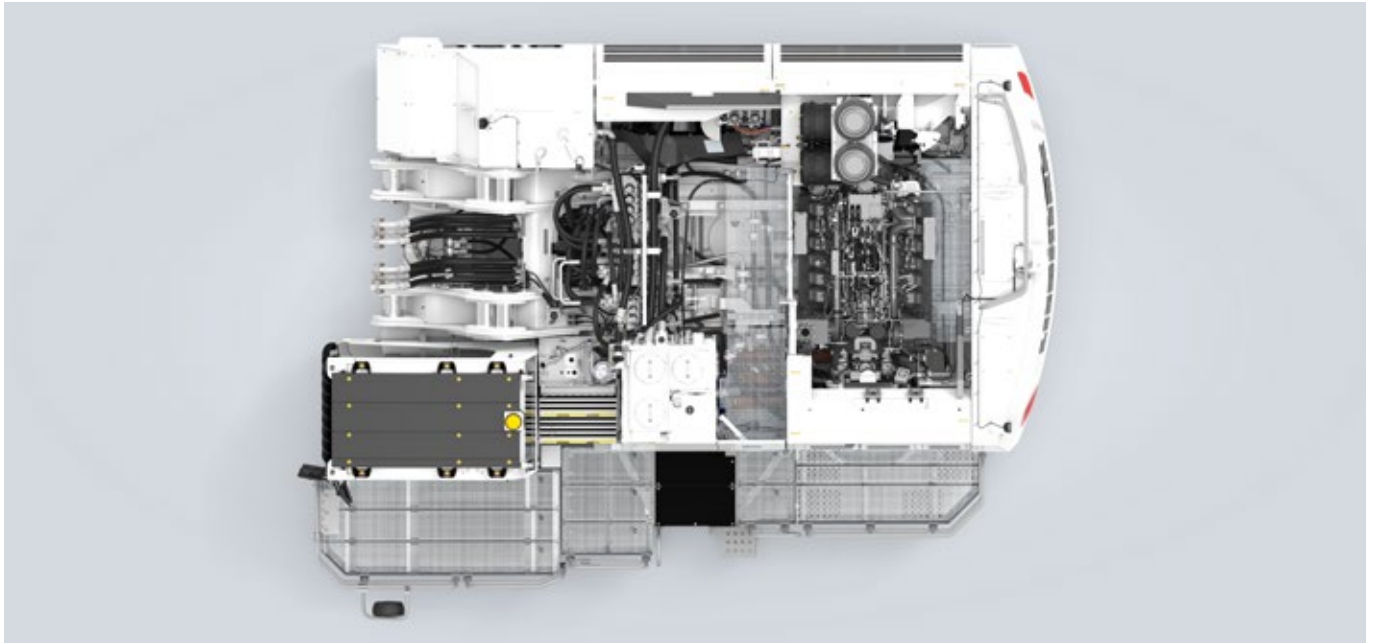

Automatic greasing system

- Grease tank for the attachment, uppercarriage and swing ring bearing
- Grease tank for the swing ring teeth
- Simplified component layout
- Automatic greasing cycles
- Reduced number of injectors & hoses



Superior engine accessibility

- Central service area
- Maintenance-friendly maintenance items installation
- Wide catwalks with slip-resistant surfaces



Ease of troubleshooting

- Control system hardware and software completely developed and managed by Liebherr
- Reduced number of connections and connectors

Optional

- Increased fuel tank capacity (24h operation)

- Steel grease lines on swing ring
- Swing ring scrapers

- Banlaw or Wiggins couplings
- Piston rod guards



36,000
Operational hours

Reliability

Long-lasting performances

Vertical integration

As an OEM, Liebherr has built a solid reputation for its development and production of high quality strategic mining components. The R 9150 integrates robust and reliable mining optimised components that are developed and manufactured by Liebherr, which ensures the best reliability and highest performance.

Quality: the Liebherr trademark

Providing reliable machinery is the highest priority for Liebherr mining. Utilised in tough mining applications all around the world, our R 9150 is built to last over 36,000 operational hours. Liebherr's engineering expertise and continuous improvement programs combine to deliver industry leading machines.

Super structure

- Optimised welding penetration
- Increased structural rigidity and life
- Heavy duty conception through advanced 3D design and validation softwares

Robust undercarriage

- Heavy-duty conception with durable side frame links
- Standard one-piece or optional three-pieces undercarriage for easier transport
- Fatigue resistant steel structure design
- Travel motors with standard rock protection
- Large track pads choice

Mining know-how

Liebherr mining excavators are conceptualised, designed and dedicated to the mining industry. The engineering department uses specific 3D simulation solutions in order to meet possible requirements, such as finite element and fatigue life analysis.

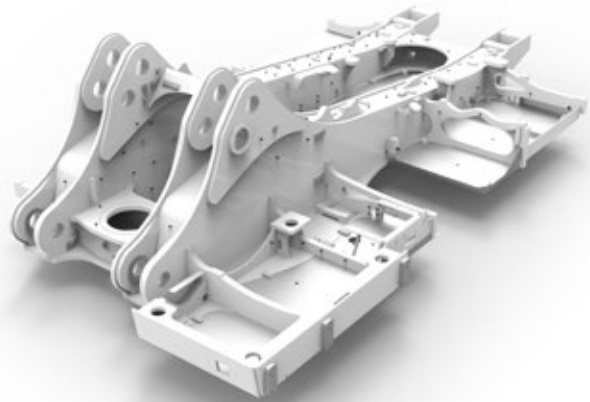

The four pillars of the Liebherr mining division

With more than 50 years of experience in the mining industry, Liebherr has identified four key factors of customer satisfaction: Performance, Safety, Service, and Sustainability. These pillars provide structure and focus for all our activities, and embody Liebherr's customer commitments.





Performance

Productive, efficient and reliable



Safety

Protecting your most important assets



Service

Where you need it, when you need it



Sustainability

Committed to our future



Technical data

Powertrain

1 Liebherr diesel engine	
Rating per ISO 9249	565 kW (757 HP) at 1,800 rpm
Model	Liebherr D9512 (US EPA Tier 4f / EU Stage V compliant or fuel consumption optimized setting)
Type	V12 cylinder engine
Bore / Stroke	128 / 157 mm / 5.04 / 6.18 in
Displacement	24.24 l / 1,479 in ³
Engine operation	4-stroke diesel common-rail direct injection turbo-charged
Cooling	water-cooled and air-cooled charge air, hydrostatic fan drive
Liebherr Power Efficiency – Engine Control	engine management systems adapting the power specifically to the load profile
Air cleaner	dry-type air cleaner, primary and safety elements, automatic dust discharge
Fuel tank capacity	1,984 l / 524 gal
Engine idling	automatic idle control
Electrical system	
Voltage	24 V
Batteries	4 x 75 Ah / 12 V
Starter	24 V / 2 x 8.4 kW
Alternator	24 V / 140 A for US EPA Tier 2 engine and 24 V / 160 A for US EPA Tier 4f / EU Stage V engine
RPM adjustment	step by step via rpm selector
or	
1 electric motor	
Power output	565 kW (757 HP)
Type	3-phase AC squirrel cage motor
Voltage	6,000 V, other voltage on request
Frequency	50 Hz (or 60 Hz)
Revolutions	1,500 rpm or 1,800 rpm
Motor cooling	integrated air-to-air heat exchanger
Starting method	inrush current limited to 2.2 full load current

Electro-hydraulic controls

Servo circuit	independent, electronic over hydraulic proportional controls of each functions
Emergency control	via accumulator for all attachment functions with stopped engine
Power distribution	via monoblock control valves with integrated primary and secondary relief valves
Flow summation	to attachment and travel drive
Closed-loop circuit	for uppercarriage swing drive
Attachment and swing	proportional via electronic joystick levers
Travel	proportional via electronic pedals or removable hand levers
Shovel flap functions	proportional via electronic pedals
Electronic dampening system	Liebherr designed electronic control of cylinder position via inertial measurement units

Swing drive

Hydraulic motor	2 Liebherr axial piston motors
Swing gear	2 Liebherr planetary reduction gears
Swing ring	Liebherr, sealed triple roller swing ring, internal teeth
Swing speed	0 – 6.5 rpm
Swing-holding brake	wet multi-disc brakes, spring applied, hydraulically released

Hydraulic system

Hydraulic pump for attachment and travel drive	3 Liebherr variable flow axial piston pumps
Max. flow	3 x 512 l/min. / 3 x 135 gpm
Max. pressure	350 bar / 5,076 psi
for swing drive	1 Liebherr reversible swashplate pump, closed-loop circuit
Max. flow	643 l/min. / 170 gpm
Max. pressure	350 bar / 5,076 psi
Pump management	electronically controlled pressure and flow management with oil flow optimisation
Hydraulic tank capacity	1,200 l / 317 gal
Hydraulic system capacity	1,631 l / 431 gal
Hydraulic oil filter	1 high pressure safety filter after each high pressure pump + extra-fine filtration of entire return flow with integrated by-pass filtration (15/5 µm) + dedicated leak-oil filtration
Hydraulic oil cooler	1 separated cooler, temperature controlled fan driven via 1 hydraulic piston motor
Liebherr Power Efficiency – Hydraulic Control	hydraulic management system adapting the hydraulic flow specifically to the load profile

Electric system

Electric isolation	easy accessible battery isolators
Working lights	high brightness LED lights: - 2 on working attachment - 2 on cabin - 2 on RHS of uppercarriage - 3 on LHS of uppercarriage
Emergency stop switches	in the cab and in engine compartment
Electrical wiring	heavy duty execution in IP 65 standard for operating conditions of -50 °C to 100 °C / -58 °F to 212 °F

Uppercarriage

Design	torque resistant modular design upper frame
Attachment mounting	parallel length girders
Catwalks	large catwalk on the left-hand side with ladder

Cab

Design	sound insulated, tinted windows, front window armored glass, door with sliding window
Operator's seat	air suspended, body-contoured with shock absorber, adjustable to operator's weight
Joysticks	joystick levers integrated into armrest of seat, armrest adjusted to seat position
Condition monitoring	machine condition monitoring system with error reporting and operational information
Display	color LCD-display with low and high brightness settings, 1 additional fixation for supplementary customer device
Vision system	camera installation on counterweight and right-hand side of the uppercarriage, displayed over the LCD-display
Heating system / Air conditioning	standard automatic air conditioning, contains fluorinated greenhouse gases HFC 134a with a Global Warming Potential (GWP) of 1430, the AC circuit contains 1.7 kg / 3.8 lb of HFC-134 representing an equivalent of 2.4 tonnes / 2.7 tons of CO ₂ , combined cooler / heater, additional dust filter in fresh air / recirculated
Noise level (ISO 6396)	Diesel: L _{PA} (inside cab) = 74 dB(A)
Hand-arm vibrations	≤ 2.5 m/s ²
Whole-body vibrations	≤ 0.5 m/s ²

Undercarriage

Version HD	heavy duty
Drive	Liebherr swashplate motors
Travel gear	Liebherr planetary reduction gears
Travel speed	0 - 2.9 km/h / 0 - 1.80 mph
Track components	track pitch 280 mm / 11.02 in, maintenance-free
Track rollers / Carrier rollers	9 / 2 per side frame
Track pads	double grouser
Track tensioner	spring with grease tensioner
Parking brake	wet multi-discs (spring applied, pressure released)
Brake valves	integrated in main valve block

Central lubrication system

Type	single line lubrication system, for the entire attachment / swing ring bearing and teeth
Grease pumps	1 hydraulic pump for attachment / swing ring bearing lubrication, 1 electric pump for swing teeth lubrication
Capacity	80 l / 21.1 gal bulk container for attachment / swing ring bearing, separated 8 l / 2.1 gal container for swing ring teeth
Refill	via quick connections and grease filters for both containers

Attachment

Design	box-type, combination of resistant steel plates and cast steel components
Hydraulic cylinders	Liebherr design, electronically controlled end-cushioning
Hydraulic connections	pipes and hoses equipped with SAE flange connections
Pivots	sealed, low maintenance
Pivots bucket-to-stick Pivots bucket-to-link	O-ring sealed and completely enclosed

Dimensions

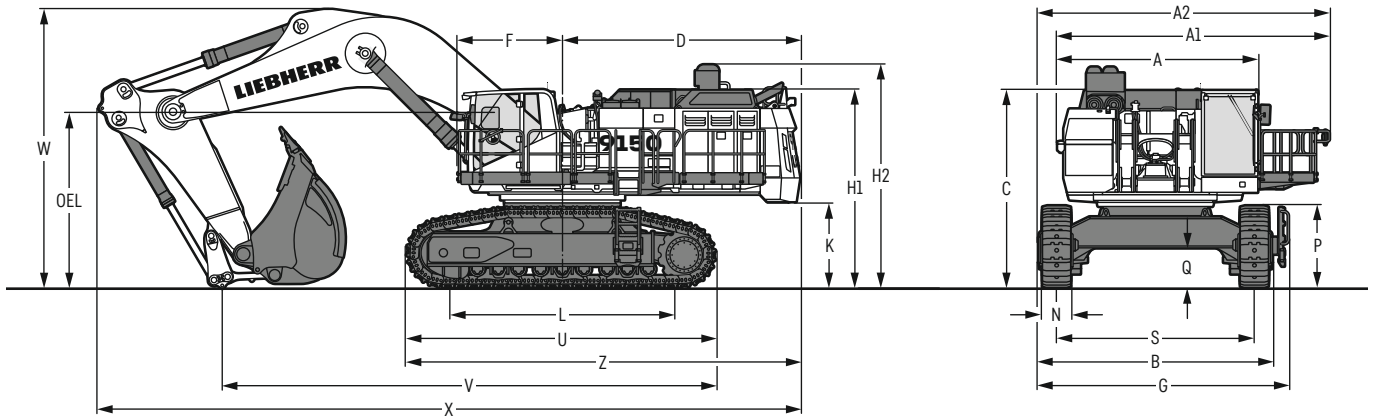

	mm / ft in
A	4,318 / 14'2"
A1	5,702 / 18'7"
A2	6,105 / 20'
B	4,995 / 16'4"
C	4,230 / 13'4"
D	5,060 / 16'6"
F	2,233 / 7'3"
G	5,355 / 17'6"
H1	4,225 / 13'9"
H2	4,930 / 16'2"

	mm / ft in
K	1,840 / 6'
L	5,200 / 17'1"
N	500 / 1'6" 600 / 2' 750 / 2'5"
P	1,748 / 5'7"
Q	852 / 2'8"
S	4,230 / 13'9"
U	6,610 / 21'7"
Z	8,365 / 27'4"
OEL (Operator's eye level)	3,614 / 11'9"

	Stick length m / ft in	Mono boom	Mono boom	Mono boom
		7.40 m / 24'3" mm / ft in	7.80 m / 25'6" mm / ft in	9.30 m / 30'5" mm / ft in
V	3.40 / 11'2"	10,400 / 34'1"	10,550 / 34'6"	12,140 / 39'8"
	4.60 / 15'1"	- / -	- / -	10,225 / 33'5"
	5.70 / 18'7"	- / -	- / -	10,450 / 34'3"
W	3.40 / 11'2"	6,250 / 20'5"	6,320 / 20'7"	6,145 / 20'2"
	4.60 / 15'1"	- / -	- / -	7,130 / 23'4"
	5.70 / 18'7"	- / -	- / -	8,025 / 26'3"
X	3.40 / 11'2"	14,550 / 47'7"	15,000 / 49'2"	16,500 / 54'1"
	4.60 / 15'1"	- / -	- / -	15,700 / 51'5"
	5.70 / 18'7"	- / -	- / -	15,145 / 49'7"

Backhoe attachment (standard)

with boom 7.80 m / 25'6"

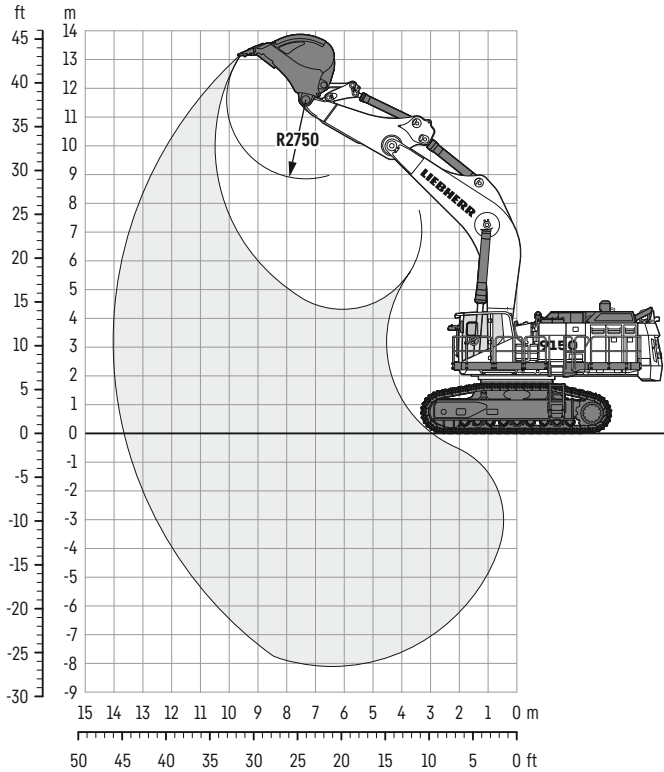

Digging envelope

Stick length	m	3.40
	ft in	11'2"
Max. digging depth	m	8.10
	ft in	26'6"
Max. reach at ground level	m	13.65
	ft in	44'8"
Max. dumping height	m	8.84
	ft in	29'
Max. teeth height	m	13.20
	ft in	43'3"

Forces

Max. digging force (ISO 6015)	kN	530
	lbf	119,149
Max. breakout force (ISO 6015)	kN	620
	lbf	139,382

Operating weight and ground pressure

The operating weight includes the basic machine with boom 7.80 m / 25'6", stick 3.40 m / 11'2" and bucket 8.80 m³ / 11.5 yd³.

		HD	
		600	750
Undercarriage			
Pad width	mm	600	750
	ft in	2'	2'5"
Weight	kg	129,700	133,100
	lb	285,939	293,435
Ground pressure*	kg/cm ²	1.90	1.56
	psi	27.02	22.19

* according to ISO 16754

Backhoe buckets

For materials class according to VOB, Section C, DIN 18300		< 5	< 5	5 - 6	5 - 6	5 - 6	7 - 8	7 - 8	7 - 8
Typical operation according to VOB, Section C, DIN 18300		GP	GP	HD	HD	HD	XHD	XHD	XHD
Capacity ISO 7451	m ³	10.60	9.60	9.60	8.80	8.00	8.80	8.00	6.80
	yd ³	13.9	12.6	12.6	11.5	10.5	11.5	10.5	8.9
Suitable for material up to a specific weight of	t/m ³	1.5	1.7	1.6	1.8	2.0	1.7	1.9	2.3
	lb/yd ³	2,528	2,865	2,697	3,034	3,371	2,865	3,203	3,877
Weight	kg	7,700	7,440	8,280	7,810	7,630	8,650	8,350	7,950
	lb	16,976	16,402	18,254	17,218	16,821	19,070	18,409	17,527

GP: General purpose bucket with Liebherr Z100 teeth

HD: Heavy-duty bucket with Liebherr Z110 teeth

XHD: Heavy-duty rock bucket with Liebherr Z110 teeth

Backhoe attachment

with boom 7.40 m / 24'3"

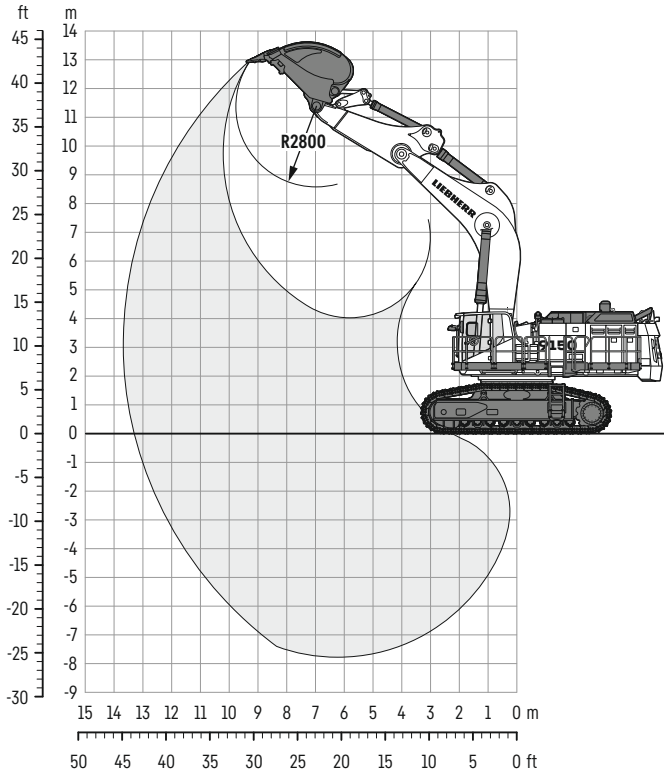

Digging envelope

Stick length	m	3.40
	ft in	11'2"
Max. digging depth	m	7.80
	ft in	25'6"
Max. reach at ground level	m	13.30
	ft in	43'6"
Max. dumping height	m	8.60
	ft in	28'2"
Max. teeth height	m	13.00
	ft in	42'7"

Forces

Max. digging force (ISO 6015)	kN	522
	lbf	117,350
Max. breakout force (ISO 6015)	kN	603
	lbf	135,560

Operating weight and ground pressure

The operating weight includes the basic machine with boom 7.40 m / 24'3", stick 3.40 m / 11'2" and bucket 9.60 m³ / 12.6 yd³.

		HD	
		600	750
Undercarriage			
Pad width	mm	600	750
	ft in	2'	2'5"
Weight	kg	130,000	133,400
	lb	286,001	294,096
Ground pressure*	kg/cm ²	1.90	1.56
	psi	27.02	22.19

* according to ISO 16754

Backhoe buckets

For materials class according to VOB, Section C, DIN 18300		< 5	< 5	5 - 6	5 - 6	5 - 6	7 - 8	7 - 8	7 - 8
Typical operation according to VOB, Section C, DIN 18300		GP	GP	HD	HD	HD	XHD	XHD	XHD
Capacity ISO 7451	m ³	11.70	10.60	10.00	9.60	8.80	9.20	8.30	7.60
	yd ³	15.3	13.9	13.1	12.6	11.5	12.0	10.9	9.9
Suitable for material up to a specific weight of	t/m ³	1.5	1.7	1.7	1.8	2.0	1.8	2.0	2.2
	lb/yd ³	2,528	2,865	2,865	3,034	3,371	3,034	3,371	3,708
Weight	kg	8,050	7,700	8,500	8,280	7,810	8,950	8,750	8,600
	lb	17,747	16,976	18,739	18,254	17,218	19,731	19,290	18,960

GP: General purpose bucket with Liebherr Z100 teeth

HD: Heavy-duty bucket with Liebherr Z110 teeth

XHD: Heavy-duty rock bucket with Liebherr Z110 teeth

Backhoe attachment

with boom 9.30 m / 30'5"

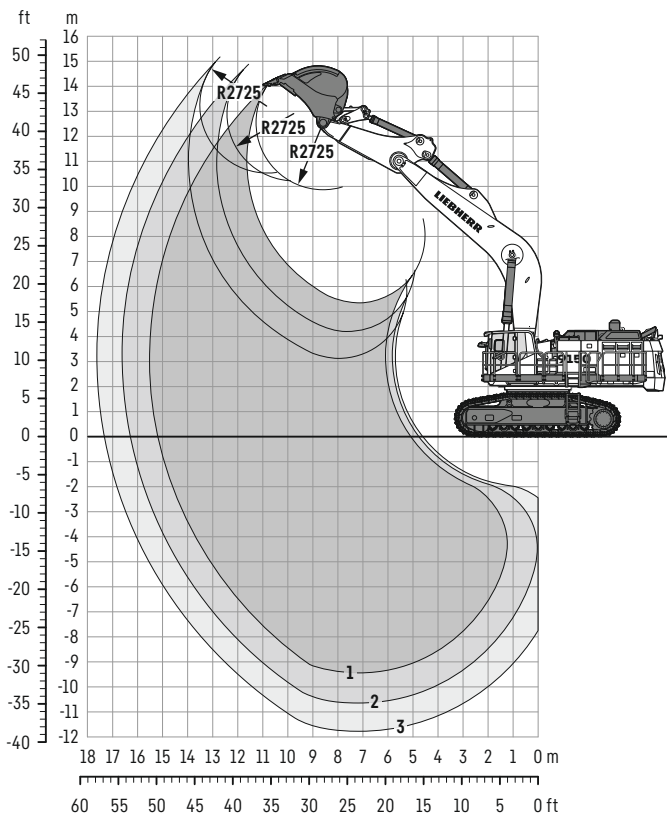

Digging envelope

		1	2	3
Stick length	m	3.40	4.60	5.70
	ft in	11'2"	15'1"	18'7"
Max. digging depth	m	9.45	10.65	11.80
	ft in	31'	34'9"	38'7"
Max. reach at ground level	m	15.20	16.30	17.35
	ft in	49'9"	53'5"	56'9"
Max. dumping height	m	9.85	10.20	10.50
	ft in	32'3"	33'5"	34'4"
Max. teeth height	m	14.15	14.90	15.20
	ft in	46'4"	48'9"	49'9"

Forces

		1	2	3
Max. digging force (ISO 6015)	kN	530	440	390
	lbf	119,149	98,916	87,676
Max. breakout force (ISO 6015)	kN	620	620	620
	lbf	139,382	139,382	139,382

Operating weight and ground pressure

The operating weight includes the basic machine with boom 9.30 m / 30'5", stick 4.60 m / 15'1" and bucket 5.00 m³ / 6.5 yd³.

		HD	
		600	750
Undercarriage	Pad width	600	750
	ft in	2'	2'5"
Weight	kg	132,300	135,700
	lb	291,671	299,167
Ground pressure*	kg/cm ²	1.93	1.59
	psi	27.45	22.62

* according to ISO 16754

Backhoe buckets

For materials class according to VOB, Section C, DIN 18300	< 5	< 5	5 - 6	5 - 6	5 - 6	7 - 8	
Typical operation according to VOB, Section C, DIN 18300	GP	GP	HD	HD	HD	XHD	
Capacity ISO 7451	m ³	5.50	6.50	4.20	5.00	6.00	4.20
	yd ³	7.2	8.5	5.5	6.5	7.8	5.5
Suitable for material up to a specific weight of							
with stick 3.40 m	t/m ³	-	1.6	-	2.2	1.8	2.2
with stick 11'2"	lb/yd ³	-	2,697	-	3,708	3,034	3,708
with stick 4.60 m	t/m ³	1.6	1.3	2.1	1.8	1.3	2.0
with stick 15'1"	lb/yd ³	2,697	2,191	3,540	3,034	2,191	3,371
with stick 5.70 m	t/m ³	1.4	-	1.8	1.5	-	1.6
with stick 18'7"	lb/yd ³	2,360	-	3,034	2,528	-	2,697
Weight	kg	6,500	7,000	6,600	6,800	7,200	7,300
	lb	14,330	15,432	14,551	14,991	15,873	16,094

GP: General purpose bucket with Liebherr Z100 teeth

HD: Heavy-duty bucket with Liebherr Z110 teeth

XHD: Heavy-duty rock bucket with Liebherr Z110 teeth

Dimensions

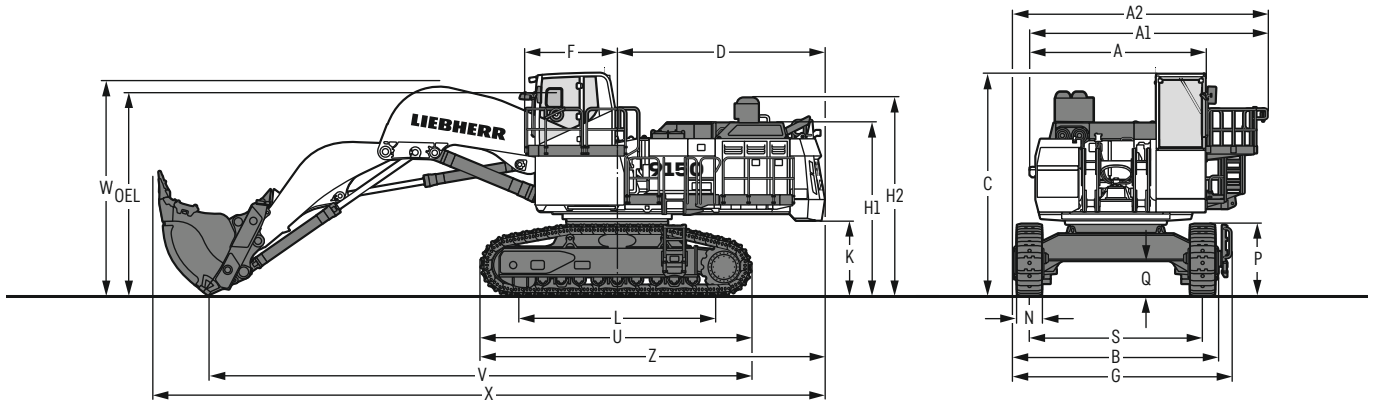

	mm / ft in		mm / ft in		mm / ft in		mm / ft in
A	4,318 / 14'2"	F	2,233 / 7'3"		500 / 1'6"	U	6,610 / 21'7"
A1	5,702 / 18'7"	G	5,355 / 17'6"	N	600 / 2'	V1	13,250 / 43'5"
A2	6,105 / 20'	H1	4,225 / 13'9"		750 / 2' 5"	W1	5,265 / 17'3"
B	4,995 / 16'4"	H2	4,930 / 16'2"	P	1,748 / 5'7"	X1	16,400 / 53'8"
C	5,430 / 17'8"	K	1,840 / 6'	Q	852 / 2'8"	Z	8,365 / 27'4"
D	5,060 / 16'6"	L	5,200 / 17'1"	S	4,230 / 13'9"	OEEL (Operator's eye level)	4,814 / 15'8"

Face shovel attachment

with boom 5.30 m / 17'4"

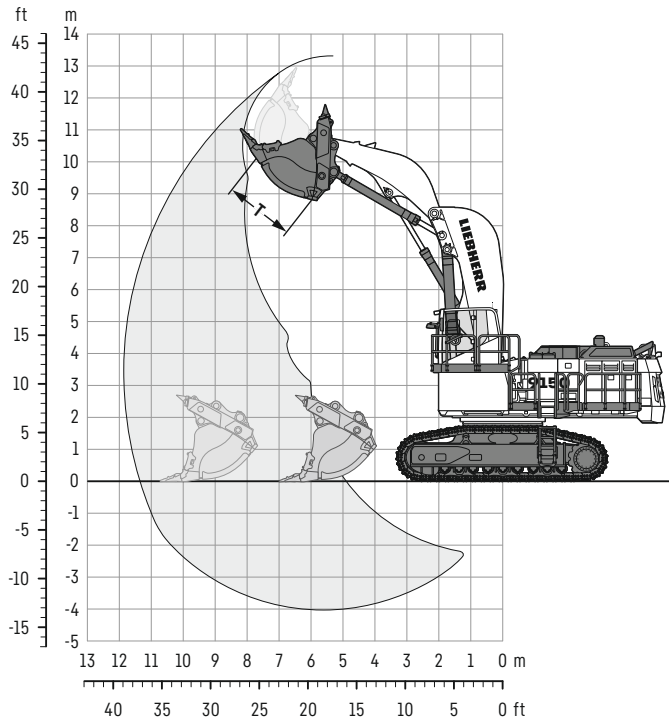

Digging envelope

Stick length	m	3.80
	ft in	12'5"
Max. reach at ground level	m	11.39
	ft in	37'4"
Max. dumping height	m	8.80
	ft in	28'9"
Max. crowd length	m	4.03
	ft in	13'2"
Bucket opening width T	mm	2,150
	ft in	7'1"

Forces

Max. crowd force at ground level (ISO 6015)	kN	640
	lbf	143,878
Max. crowd force (ISO 6015)	kN	750
	lbf	168,607
Max. breakout force (ISO 6015)	kN	630
	lbf	141,630

Operating weight and ground pressure

The operating weight includes the basic machine with shovel attachment and bucket 8.30 m³ / 10.9 yd³.

		HD	
		600	750
Undercarriage			
Pad width	mm	600	750
	ft in	2'	2'5"
Weight	kg	130,000	133,400
	lb	286,001	294,097
Ground pressure*	kg/cm ²	1.90	1.56
	psi	27.02	22.20

* according to ISO 16754

Face shovel buckets

For materials class according to VOB, Section C, DIN 18300	< 5	< 5	5 - 6	5 - 6	5 - 6	5 - 6	7 - 8	7 - 8	7 - 8
Typical operation according to VOB, Section C, DIN 18300	GP	GP	HD	HD	HD	HD	XHD	XHD	XHD
Capacity ISO 7451	m ³	9.30	8.90	8.90	8.30	7.70	7.00	8.30	7.70
	yd ³	12.2	11.6	11.6	10.9	10.1	9.2	10.9	10.1
Suitable for material up to a specific weight of	t/m ³	1.6	1.7	1.6	1.8	2.0	2.4	1.7	1.85
	lb/yd ³	2,697	2,865	2,697	3,034	3,371	4,045	2,865	3,118
Cutting width	mm	2,900	2,900	2,900	2,900	2,900	2,600	2,900	2,900
	ft in	9'5"	9'5"	9'5"	9'5"	9'5"	8'5"	9'5"	9'5"
Weight	kg	13,500	13,100	14,020	13,250	12,920	11,550	14,180	13,800
	lb	29,762	28,881	30,909	29,211	28,484	25,463	31,262	30,424

GP: General purpose bucket with Liebherr Z100 teeth

HD: Heavy-duty bucket with Liebherr Z110 teeth

XHD: Heavy-duty rock bucket with Liebherr Z110 teeth

Optional equipment

Undercarriage

Narrow track pad width

Large track pad width

Removable side frames

Rock protection for travel drive

Protection for undercarriage center frame

Rock protection for idler wheel

Rock protection for sprocket

Full length chain guide

Uppercarriage

Hydraulically operated 45° access stair

Electric-powered refueling pump

Increased fuel tank capacity (24h operation)

Grid protection for front headlights

Semi-automatic swing brake with joystick control

Rock protection for swing gear and grease lines

Wiggins fast fueling system

Wiggins fast fueling pressureless system with Multiflo Hydrau-Flo®

Wiggins couplings for ground level access service

Steel grease lines on swing ring

Swing ring scrapers

External grease refill station (hydraulic-powered)

Hydraulic connection with quick coupler for external grease refill station

Right-hand bumper

External starting device

Hydraulic system

Oil cooler inlet screen

Cab

4-point seat belt

Cab elevation (500 mm / 1'6" / 1,200 mm / 3'9" / 1,600 mm / 5'3")

Cab pressurization

Cab pressurization with HEPA filter

FOPS top guard with additional sun protection

Operator comfort package

Front protective grid

Programmable pre-heating system for cab

Roof glazing

External louvers

Assistance systems

Truck Loading Assistant

Operational Analytics

Automation

Bucket Filling Assistant

Attachment

Piston rod guard for bucket cylinder (BH)

Piston rod guard for hoist cylinder (BH/FS)

Piston rod guard for stick cylinder (FS)

Specific solutions

Arctic package (-20 °C / -4 °F, -35 °C / -31 °F, -50 °C / -58 °F)

Sound attenuation package

Safety

Additional LED lighting with timer (for main access)

Automatic fire fighting system

Additional emergency stop (ground level)

Travel Alarm "Lynx shout"

Isolation & energy dissipation system for uppercarriage – MDG 41 compliant

General

Maritime transport packaging

Electric drive

Automatic cable reeler



Mining excavator



Mining truck



Mining dozer



Mining dragline



Service tools



Customer service

Quality commitment

- Liebherr-Mining Equipment Colmar, France, ISO 9001 certified
- Compliance of materials tested in laboratory
- Quality control during all stages of production
- CE certified, MDG 15 & MDG 41 compliant

Subject to technical modifications. All comparisons and claims of performance are made with respect to the prior Liebherr model unless specifically stated.

Liebherr-Mining Equipment Colmar SAS

49 rue Frédéric Hartmann • 68025 Colmar Cedex, France • Phone +33 369 49 20 00
info.lec@liebherr.com • www.liebherr.com • www.facebook.com/LiebherrMining