

R 9200

Generation 7

LIEBHERR

Mining excavator



Technologies

- Assistance systems
- Liebherr power efficiency
- Bucket filling assistant

Powertrain options

- Cummins: 810 kW (FCO, Tier 4f)
1,086 HP
- Electric: 850 kW (50 Hz, 60 Hz)
1,139 HP

Backhoe configuration

- Overall weight: 205 tonnes
225 tons
- Bucket payload: 22.5 tonnes
25 tons

Face shovel configuration

- Overall weight: 210 tonnes
231 tons
- Bucket payload: 22.5 tonnes
25 tons

Overview

R 9200



Diesel drive 810 kW / 1,086 HP
Electric drive 850 kW / 1,139 HP



BH 12.5 m³ / 16.4 yd³
FS 12.5 m³ / 16.4 yd³



BH 205 tonnes / 225 tons
FS 210 tonnes / 231 tons

Patented EVO bucket

Stress-relieved structure

The R 9200 is the optimal loading excavator to load 65 t and 130 t off-highway trucks. The R 9200 can meet any customer requirement thanks to leading technology. High productivity, exceptional reliability and true 200 t class performance make the R 9200 a world-class loading tool.

Standard heavy-duty bucket

- Highest bucket capacity in its class with proven EVO bucket design
- Maximised payload with versatile Liebherr bucket solution
- Shift levers and bucket links with integrated greasing system

Perfect shovel truck match

- 3 pass loading of 65 tonne trucks
- 5 pass loading of 90-100 tonne trucks
- 6 pass loading of 130 tonne trucks



High performance execution

Latest cutting-edge technologies

Sustainable & efficient performance

Latest cabin generation

- Increased comfort and ergonomics
- User-friendly operator station
- Elevated cab installation
- Suspended operator seat
- Slim line dash and LED lighting

Latest cutting-edge technologies

- Liebherr assistance systems
- Advanced machine monitoring with modern 15" touchscreens (day & night mode)
- Permanent vision system

Sustainable performance

- US EPA Tier 4f / EU Stage V compliant engine
- SCR after-treatment technology
- Serial implementation Liebherr power efficiency solutions
- Electric drive version

Performance & sustainability

Powertrain



+25 %
Fuel efficiency



Diesel drive

Cummins QSK38

810 kW / 1,086 HP at 1,800 RPM
12 cylinder V-engine
Displacement 37.8 l / 2,307 in³

US EPA Tier 4f / EU Stage V

Using selective catalytic reduction technology to comply with latest emission regulations the R 9200 combines flexibility to meet customer expectations without compromising productivity.



Electric drive

Liebherr offers an alternative to diesel engines allowing customers to balance performance with environmental consciousness. Building on 30 years' experience in electric drive excavators, the electric drive option allows lower maintenance costs and reduced noise pollution. With high motor efficiency, the electric drive gives maximum performance.

- Lower maintenance costs
- 6,000 V (50 Hz other voltage and frequency on request)
- Integrated design elements on all machine structures
- Optional cable reeler

No exhaust emission

Liebherr electric R 9200 provides class leading cycle times using electric motors without exposing people and the environment to diesel exhaust emissions. Complying with all Non Road Mobile Machinery (NRMM) emission regulations, the R 9200 E can be operated all around the world.

Less noise level

Liebherr Electric driven machines can be operated without restrictions in noise sensitive areas.



Productivity

Attachment

Build for maximum productivity

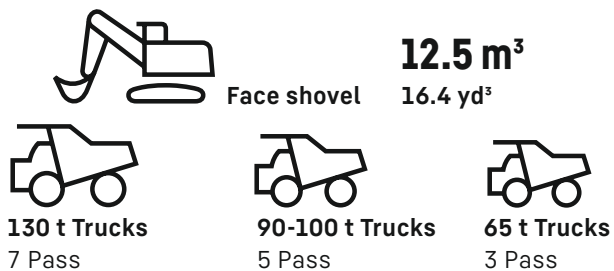
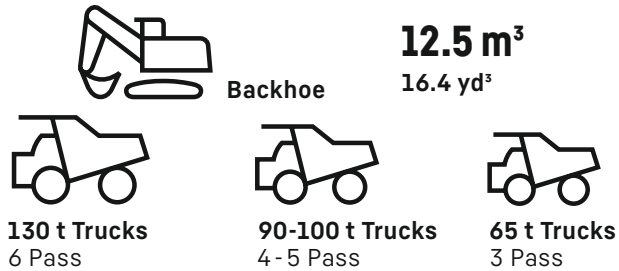

Maximised payload

Designed for best force distribution, the attachment design delivers high digging and hoisting forces, which ensures maximum payload during each cycle. The EVO bucket allows the operator to take advantage of each pass and therefore increase productivity.

Optimised cost per tonne

Built to outperform all competitors in its class, the R 9200 is a perfect loader for 65 t up to 130 t off-highway trucks.

*Liebherr EVO bucket compared to competitor's average bucket capacity.



+4 %
Loading capacity*



Automation

Bucket filling assistant

The first automation product of the Liebherr hydraulic excavator portfolio allows easier bucket filling and consistent bucket fill factors, especially in blocky or hard digging conditions. As a result overall productivity improves while operator's fatigue decreases.



Anti-stalling function

Prevents the bucket from being stalled during the digging phase.



Semi-automatic bucket filling function

Allows the machine electronic to realise fully automatic attachment movements.



Discover more.

Comfort

Operator cabin

Enhanced comfort & ergonomics



Advanced machine monitoring

- Modern and large touchscreens
- State-of-the-art on-board technologies
- Long term data storage for maintenance
- User-friendly piloting station
- On-board diagnostics to service staff



Superior comfort

- Tinted laminated safety glass
- Armored front window
- Adjustable air suspended seat
- Foldable trainer seat
- Pressurised A/C system (single or double)

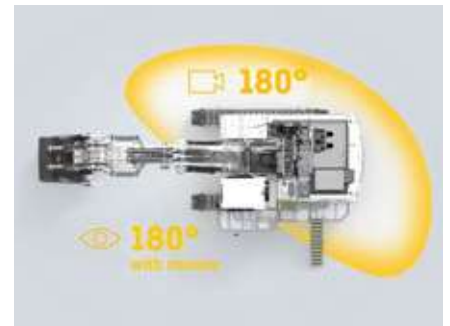

Vision system

The R 9200 offers superior visibility of the machine's surroundings. The dedicated monitor inside the cabin provides continuous rear and side vision around the machine, from the two cameras strategically fixed on the uppercarriage.



Working environment

Operator comfort

Operator comfort and safety were the main concerns when designing the R 9200 cabin: a panoramic view, low noise level, strong structure (FOPS) and high safety standards. In addition Liebherr provides options to adapt the cab to specific thermal conditions or requirements.

Optional

- Double A/C system
- External louvers
- Premium heated seats
- Four point harness
- Sliding hatch window
- Front protective grid
- HEPA filtration system



Assistance systems

The best performance. Easy.

Get the best out of your Liebherr mining excavator

Available today on the R 9200, the Liebherr assistance systems are advanced onboard applications designed to support operators to become more efficient through analytics and actionable insights. Systems will assist the operator to obtain optimal productivity and efficiency by providing realtime operational information.

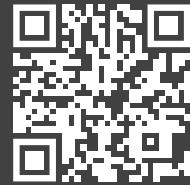

Want to live the real experience?



Measure and analyse every bucket payload for optimal truck loading



Data visualised within different views & advanced filtering



Display targeted productivity and actual payload with 99% accuracy



Provide transparency of performance, operating time and fuel efficiency



Identify operational conformance and improve operator effectiveness



State-of-the-art on-board touchscreen displays



Make informed decisions



Increase productivity

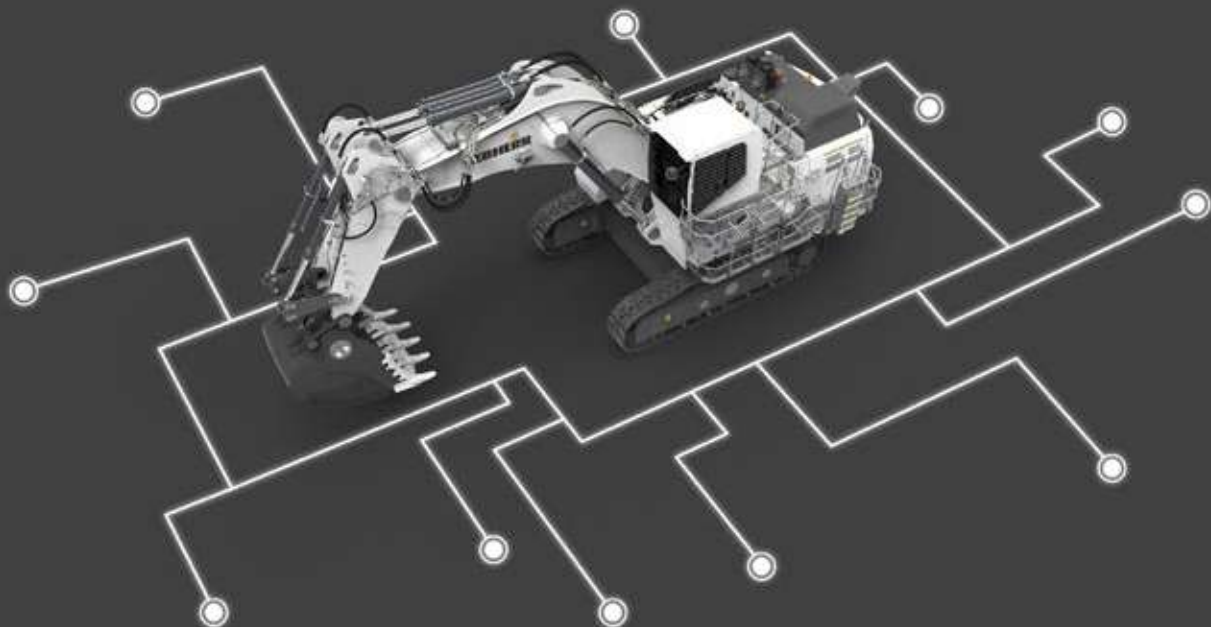



Truck loading assistant

Assists the operator to obtain target truck payloads.

With 99% measurement accuracy

- Measures instantaneously the bucket payload
- Provides real-time information to the operator
- Strategises the number of passes required
- Computes the best truck loading strategy
- Automatic truck recognition (optional)



Performance monitoring

Measures and analyses the overall performance.

Using KPIs, histograms and time-related charts

- Production KPIs
- Loading indicators
- Time distribution
- Energy efficiency



Application severity

Quantifies application, reports severity indicators and provides an overall application severity score.

KPIs to indicate and display the application as sensed by the machine

- Underfoot and digging conditions
- Abrasiveness and travel ratio
- Engine load factor and temperature variation
- Machine inclination, loading, etc.



Operational conformance

Detects and counts events to improve operator effectiveness.

Several filtering criteria to identify specific events

- Swinging into digging face
- Digging with swing brake activated
- Turning the machine with the attachment
- Bucket hitting track pads, etc.

Performance

Advanced hydraulic system

Highest
digging force

650 kN

Breakout force

740 kN

in its class



Fast & precise movement

Intelligent power management system

The Liebherr R 9200 mining excavator is equipped with a closed loop swing circuit. Kinetic energy is recovered when the swing motion is used during deceleration to drive the main and auxiliary pumps resulting in fuel consumption reduction.

Cylinder dampening through IMUs provides smoother attachment movements without affecting attachment speed.

Independent cooling system

Oil and water cooling fans are independently and electronically managed. The oversized cooling systems reduce parasitic demand on engine horsepower ensuring maximum available horsepower is provided to the excavator working circuits.

Valve bank control system

- Under slung arch hoses to improve lifetime
- Flow optimized hose fittings
- Less hydraulic pressure losses by design
- Pilot valves integrated into valve blocks



Moving more with less

Patented Liebherr power efficiency

Specific engine and hydraulic management, drastically reducing fuel consumption without any compromise on machine productivity.

- Adapted piloting processes according to operator requirements and machine condition
- Electronically controlled pressure and oil flow
- Reduce hydraulic throttling and load profile of the engine for increased component lifetime

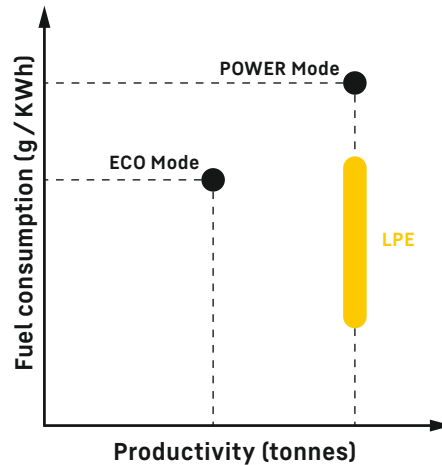

- Previous R 9200 G6
- R 9200 G7

Up to **20%**
less fuel consumption

"Adapt the power and the hydraulic flow specifically to the load profile."



Safety

Protecting your most important asset



Machine accessibility

The R 9200 is fitted with an ergonomic hydraulically controlled 45 degree stairway with handrails, providing safe access to the uppercarriage. Single side access to all service points.

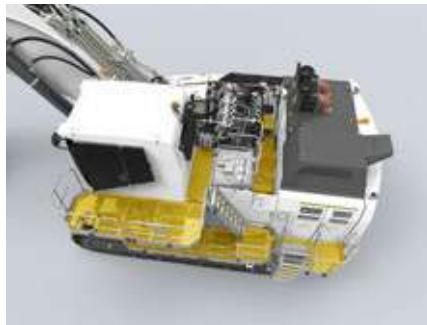

Wide catwalks for inspection

Enlarged walkways allow easy and safe access for inspection and maintenance around engine, fans, and pumps. All routine service items have been located to allow effortless inspection and replacement.



Emergency stops and emergency exits

Emergency stops are specifically located throughout the machine, increasing safety. A emergency drop-down ladder guarantees safe and quick exit from the machine.



Advanced engine fire protection

After treatment systems and turbochargers are heat shielded. The engines are mechanically segregated from hydraulic components, further improving on machine safety.

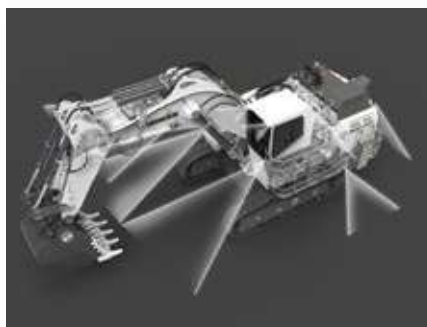

LED lighting system

Thanks to LED long-reach lights located on attachment, uppercarriage and counterweight, the machine offers best visibility to the operator and to the people / equipment around.



Safe surrounding area

Horn, LED working lights, LED service lights, LED access lights, flashing lights and travel alarm guarantee safe 24 / 7 operation and maintenance conditions.

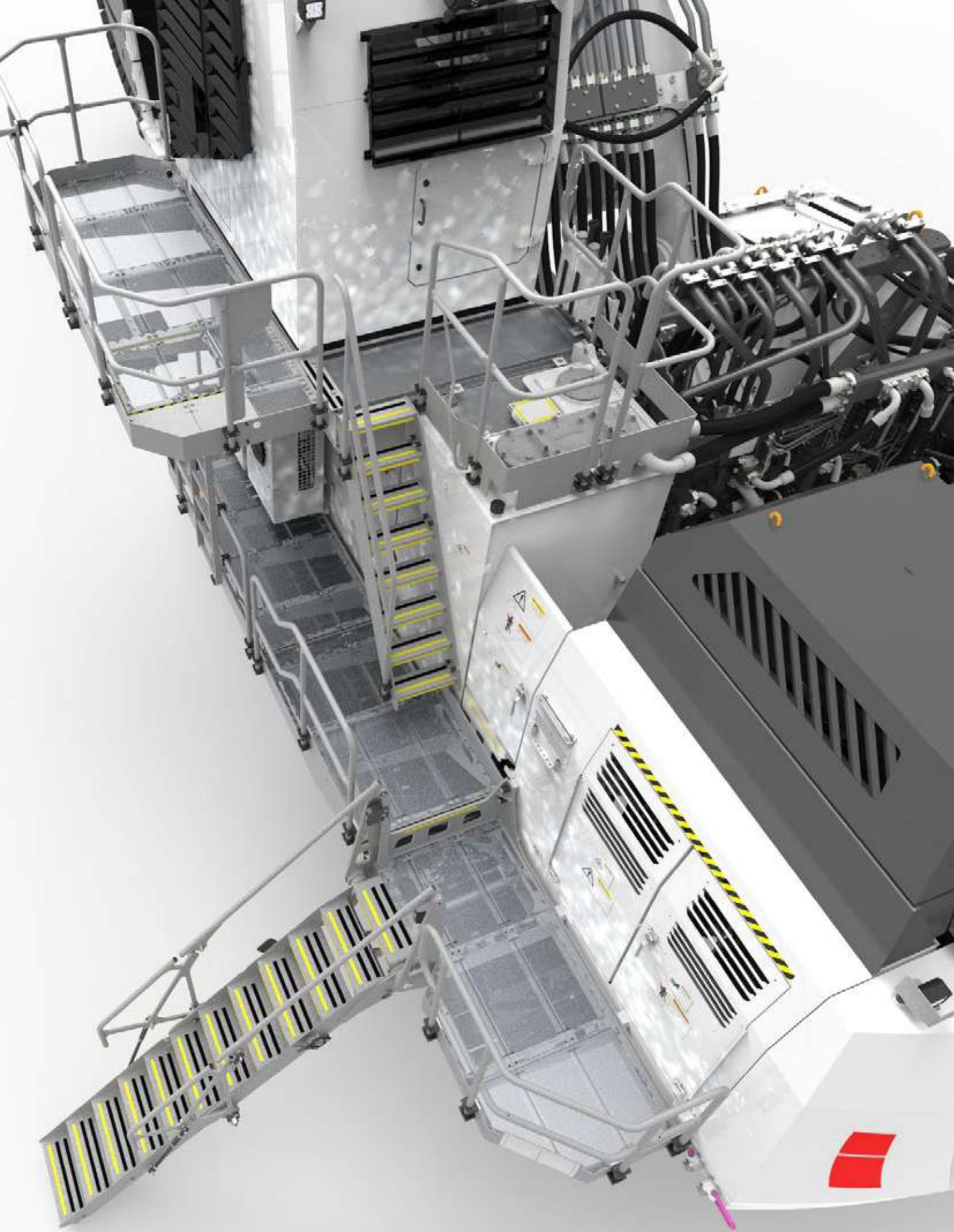

Maintenance

Easy & safe operations



24 / 7
Operations

Centralised service & service flap

Upperstructure of the R 9200 has been designed for easier maintenance and quicker servicing. The central service area provides accessibility to upperstructure fluid compartments reducing machine downtime. Refill and drain points of the

R 9200 are easily accessed from the upperstructure or directly from the ground with the service flap equipped with fast couplings and depressurized valves.



Automatic greasing system

- Grease tank for the attachment, upperstructure and swing ring bearing
- Grease tank for the swing ring teeth
- Simplified component layout
- Automatic greasing cycles
- Reduced number of injectors & hoses
- Electric shut-off valve in the refill line



Superior engine accessibility

- Central service area
- Maintenance-friendly maintenance items installation
- Wide catwalks with slip-resistant surfaces



Ease of troubleshooting

- Control system hardware and software completely developed and managed by Liebherr
- Reduced number of connections and connectors

Optional

- Rock protection for swing gear
- Undercarriage bottom cover

- Steel grease lines on swing ring
- Swing ring scrapers

- Banlaw or Wiggins couplings
- Piston rod guards
- Kidney loop filtration system



45,000
Operational hours

Reliability

Long-lasting performances

Vertical integration

As an OEM, Liebherr has built a solid reputation for its development and production of high quality strategic mining components. The R 9200 integrates robust and reliable mining optimised components that are developed and manufactured by Liebherr, which ensures the best reliability and highest performance.

Quality: the Liebherr trademark

Providing reliable machinery is the highest priority for Liebherr mining. Utilised in tough mining applications all around the world, our R 9200 is built to last over 45,000 operational hours. Liebherr's engineering expertise and continuous improvement programs combine to deliver industry leading machines.

Mining know-how

Liebherr mining excavators are conceptualised, designed and dedicated to the mining industry. The engineering department uses specific 3D simulation solutions in order to meet possible requirements, such as finite element and fatigue life analysis.

Super structure

- Optimised welding penetration
- Increased structural rigidity and life
- Heavy duty conception through advanced 3D design and validation softwares

Robust undercarriage

- Heavy-duty conception with durable side frame links
- Fatigue resistant steel structure design
- Travel motors with standard rock protection
- Large track pads choice

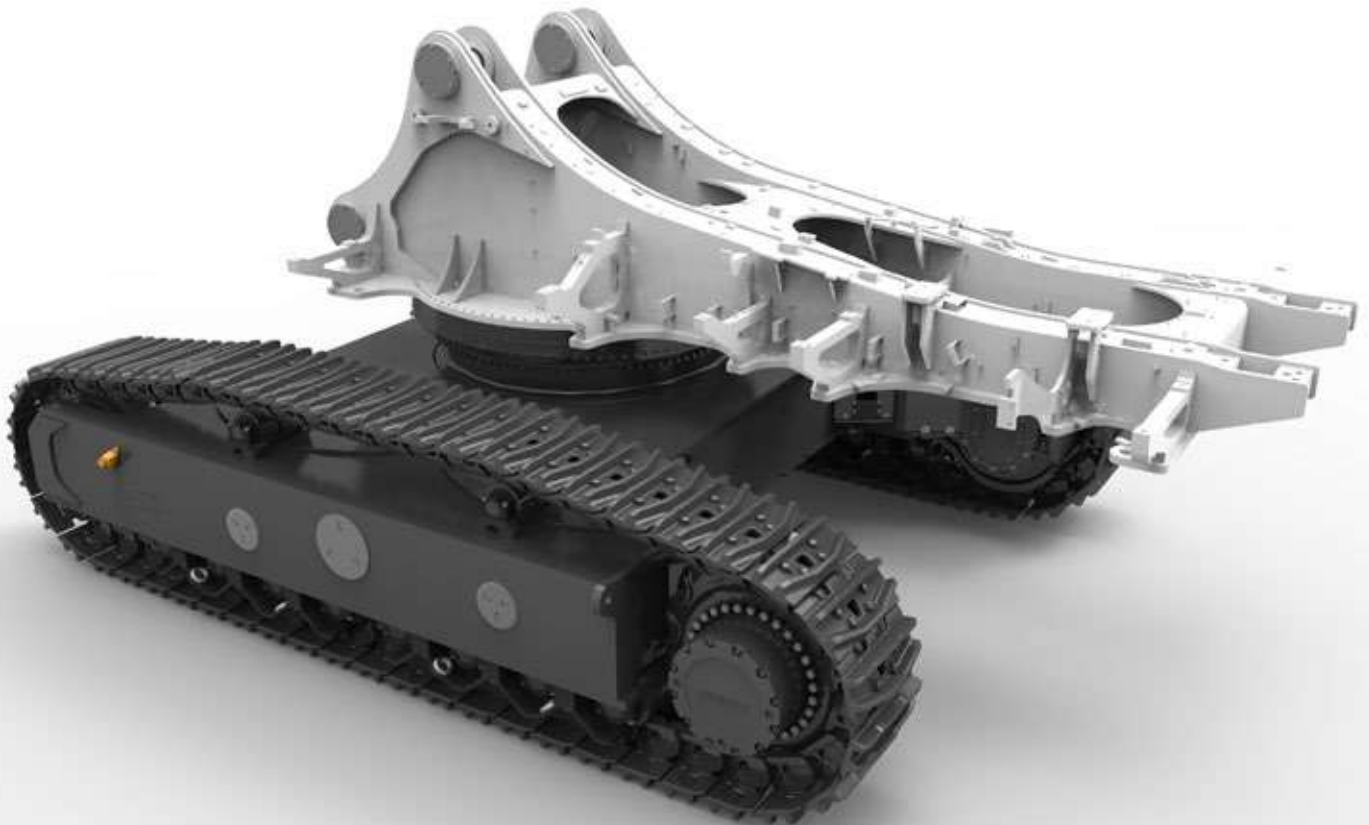

The four pillars of the Liebherr mining division

With more than 50 years of experience in the mining industry, Liebherr has identified four key factors of customer satisfaction: Performance, Safety, Service, and Sustainability. These pillars provide structure and focus for all our activities, and embody Liebherr's customer commitments.





Performance

Productive, efficient and reliable



Safety

Protecting your most important assets



Service

Where you need it, when you need it



Sustainability

Committed to our future



Technical data

Powertrain

1 Cummins diesel engine	
Rating per SAE J1995	810 kW (1,086 HP) at 1,800 rpm
Model	Cummins QSK38 (US EPA Tier 4f / EU Stage V compliant or fuel consumption optimized setting)
Type	12 cylinder V-engine
Bore / Stroke	159 / 159 mm / 6.26 / 6.26 in
Displacement	37.8 l / 2,307 in ³
Aspiration	turbocharged after cooled
Fuel tank	4,500 l / 1,189 gal
Electrical system	
Voltage	24 V, 25 V additional
Batteries	4 x 180 Ah / 12 V
Alternator	24 V / 260 Amp
Liebherr Power Efficiency – Engine Control	engine management systems adapting the power specifically to the load profile
Automatic engine shut off protection	engine self-controlled shut off 3 min.
Water cooler	cooler with temperature controlled fans driven via hydraulic piston motor
or	
1 electric motor	
Power output	850 kW (1,139 HP)
Type	3-phase AC squirrel cage motor
Voltage	6,000 V, other voltage on request
Frequency	50 Hz (or 60 Hz)
Revolutions	1,500 rpm or 1,800 rpm
Motor cooling	integrated air-to-air heat exchanger
Starting method	inrush current limited to 2.2 full load current

Electro-hydraulic controls

Servo circuit	independent, electric over hydraulic proportional controls of each function
Emergency control	via accumulator for all attachment functions with stopped engine
Power distribution	via monoblock control valves with integrated primary relief valves and flanged on secondary valves, 4 independent circuits
Flow summation	attachment and travel drive
Attachment and swing	proportional via electronic joystick levers
Travel	proportional via electronic pedals or removable hand levers
Shovel flap functions	proportional via electronic pedals
Electronic dampening system	Liebherr designed electronic control of cylinder position via inertial measurement units

Swing drive

Hydraulic motor	2 Liebherr axial piston motors
Swing gear	2 Liebherr planetary reduction gears
Swing ring	Liebherr, sealed triple roller swing ring, internal teeth
Swing speed	0 – 5.0 rpm
Swing-holding brake	hydraulically actuated, maintenance-free, multi-disc brakes integrated in each swing gear

Hydraulic system

Hydraulic pump for attachment and travel drive	4 variable flow axial piston pumps
Max. flow	4 x 512 l/min. / 4 x 135 gpm
Max. pressure	350 bar / 5,076 psi
for swing drive	1 reversible swashplate pump, closed-loop circuit
Max. flow	1 x 640 l/min. / 1 x 169 gpm
Max. pressure	350 bar / 5,076 psi
Pump management	electronically controlled pressure, flow and power management with oil flow optimisation
Hydraulic tank capacity	1,800 l / 475 gal
Hydraulic system capacity	3,400 l / 900 gal
Hydraulic oil filter	1 high pressure safety filter after each high pressure pump + extra-fine filtration of entire return flow with integrated by-pass filtration (15 / 5 µm) + dedicated leak-oil filtration
Hydraulic oil cooler	cooler with temperature controlled fans driven via hydraulic piston motor, reverse fan function
Liebherr Power Efficiency – Hydraulic Control	hydraulic management system adapting the hydraulic flow specifically to the load profile

Electric system

Electric isolation	easy accessible battery isolators
Working lights	high brightness LED lights: – 4 on cabin – 2 on working attachment with grid protection – 3 on RHS of uppercarriage – 3 on LHS of uppercarriage other: – LED service lights with timer 20 min.
Emergency stop switches	at ground level, in hydraulic compartment, in engine compartment and in operator cab
Electrical wiring	heavy duty execution in IP 65 standard for operating conditions of -50 °C to 100 °C / -58 °F to 212 °F

Uppercarriage

Design	torque resistant designed upper frame in boxtype construction for superior strength and durability
Attachment mounting	parallel longitudinal main girders in box section construction
Machine access	hydraulically operated 45° access stair, full controlled descent, in case of emergency stop additional emergency ladder fitted near the cab

Cab

Design	resiliently mounted, sound insulated, large windows for all around visibility, integrated falling object protection FOPS (ISO 10262)
Operator's seat	suspended pneumatic seat, body-contoured with shock absorber, adjustable to operator's weight, seat heating, additional "retractable passenger / trainer seat"
Cabin windows	tinted armored glass for front window and right-hand side windows, all other windows in tinted safety glass, wind-shield-washer system 30 l / 8 gal watertank, sun louvers on all windows in heavy duty design optional and frontguard optional
Heating system / Air conditioning	heavy duty, fully automatic, high output air conditioner and heater unit, contains fluorinated greenhouse gases HFC 134a with a Global Warming Potential (GWP) of 1430, the AC circuit contains 3.6 kg / 7.9 lb of HFC-134 representing an equivalent of 5.1 tonnes / 5.6 tons of CO ₂ , the 2 nd AC circuit (optional) contains 2.2 kg / 4.8 lb of HFC-134 representing an equivalent of 3.1 tonnes / 3.4 tons of CO ₂
Cabin pressurization	ventilation with filter
Controls	joystick levers integrated into armrest of seat
Monitoring	via LCD-display, data memory
Rear vision system	camera installation on counterweight and right-hand side of the uppercarriage, displayed on the monitoring display
Noise level (ISO 6396)	Diesel: L _{PA} (inside cab) = 71 dB(A)

Undercarriage

Design	3-piece undercarriage, box-type structures for center piece and side frames, stress relieved
Hydraulic motor	1 axial piston motor per side frame
Travel gear	Liebherr planetary reduction gear
Travel speed	0 - 2.8 km/h / 0 - 1.70 mph
Parking brake	hydraulically actuated, maintenance-free, multi-disc brakes for each travel motor
Track components	B 11, maintenance-free, forged double grouser pad
Track rollers / Carrier rollers	8 / 2 per side frame
Track tensioner	hydraulic and grease tensioner
Transport	undercarriage side frames are removable

Service flap

Design	manually actuated service flap, easily accessible from ground level to allow: – fuel fast refill – engine oil quick change – attachment / swing ring bearing grease barrel refilling via grease filter – 2 x swing gear oil refill – 2 x swing gear oil draining – splitterbox oil change other coupler type on request
--------	--

Central lubrication system

Type	single-line lubrication system, for the entire attachment / swing ring bearing and teeth
Grease pumps	hydraulic grease pump for the attachment / swing ring bearing, electric grease pump for the swing ring teeth
Capacity	200 l / 53 gal bulk container for attachment / swing ring bearing, separated 15 l / 4.0 gal bulk container for swing ring teeth
Refill	via the service flap for both containers, fill line with grease filters
Monitoring	via a specific Liebherr control module with data memory

Attachment

Design	box-type structure with large steel castings in all high-stress areas
Stick	wear protection underneath lower beam plate
Hydraulic cylinder	Liebherr design, electronically controlled end-cushioning
Hydraulic connections	pipes and hoses equipped with SAE flange connections
Pivots bucket-to-stick Pivots bucket-to-link	O-ring sealed and completely enclosed
Kinematics	Liebherr parallel face shovel attachment geometry, electronic controlled end-cushioning

Dimensions

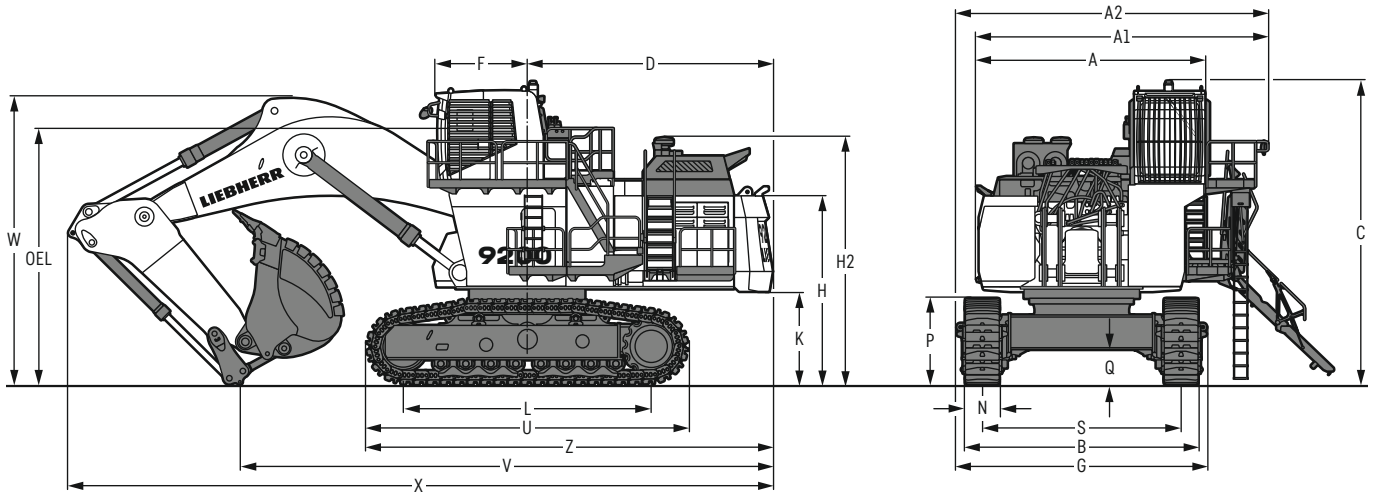

	mm / ft in
A	5,400 / 17'9"
A1	6,920 / 22'8"
A2	7,400 / 24'3"
B	5,930 / 19'5"
C	7,175 / 23'6"

	mm / ft in
D	5,800 / 19'
F	2,158 / 7'1"
H	4,440 / 14'7"
H2	5,815 / 19'1"
K	2,175 / 7'2"

	mm / ft in
L	5,862 / 19'3"
N	800 / 2'7"
P	2,040 / 6'8"
Q	837 / 2'9"
S	4,700 / 15'5"

	mm / ft in
U	7,600 / 24'11"
V	10,700 / 35' 1"
W	6,780 / 22' 3"
X	16,700 / 54' 9"
Z	9,600 / 31' 6"
OEL (Operator's eye level)	6,117 / 20' 1"

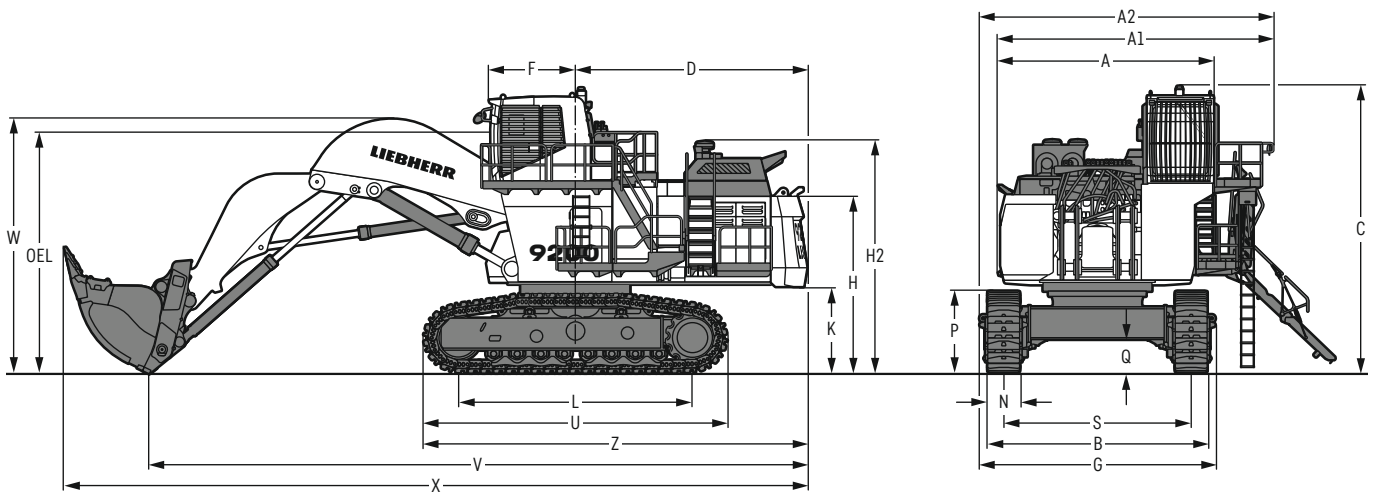

	mm / ft in
A	5,400 / 17'9"
A1	6,920 / 22'8"
A2	7,400 / 24'3"
B	5,930 / 19'5"
C	7,175 / 23'6"

	mm / ft in
D	5,800 / 19'
F	2,158 / 7'1"
H	4,440 / 14'7"
H2	5,815 / 19'1"
K	2,175 / 7'2"

	mm / ft in
L	5,862 / 19'3"
N	800 / 2'7"
P	2,040 / 6'8"
Q	837 / 2'9"
S	4,700 / 15'5"

	mm / ft in
U	7,600 / 24'11"
V	14,500 / 47' 7"
W	6,500 / 21' 4"
X	18,700 / 61' 4"
Z	9,600 / 31' 6"
OEL (Operator's eye level)	6,117 / 20' 1"

Backhoe attachment (standard)

with mono boom 8.50 m / 27'9"

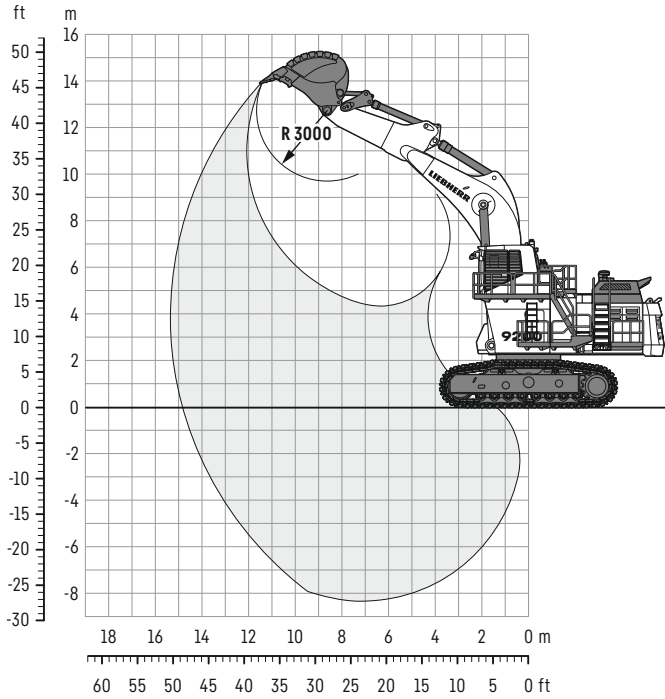

Digging envelope

Stick length	m	3.80
	ft in	12'5"
Max. digging depth	m	8.30
	ft in	27'2"
Max. reach at ground level	m	14.80
	ft in	48'7"
Max. dumping height	m	9.70
	ft in	31'10"
Max. teeth height	m	14.00
	ft in	46'

Forces

Max. digging force (ISO 6015)	kN	650
	lbf	146,126
Max. breakout force (ISO 6015)	kN	740
	lbf	166,359

Operating weight and ground pressure

The operating weight includes the basic machine with backhoe attachment and backhoe bucket 12.50 m³ / 16.35 yd³.

Pad width	mm	800
	ft in	2'6"
Weight	t	205
	sh tn	225
Ground pressure*	kg/cm ²	1.98
	psi	28.16

* according to ISO 16754

Backhoe buckets

For materials class according to VOB, Section C, DIN 18300		< 5	< 5	< 5	5 - 6	5 - 6	5 - 6	7 - 8	7 - 8	7 - 8	7 - 8
Typical operation according to VOB, Section C, DIN 18300		GP	GP	GP	HD	HD	HD	XHD	XHD	XHD	XHD
Capacity ISO 7451	m ³ yd ³	15.50 20.3	14.00 18.3	12.50 16.4	14.00 18.3	12.50 16.4	11.50 15.0	12.50 16.4	11.50 15.0	10.50 13.7	10.00 13.1
Suitable for material up to a specific weight of	t/m ³ lb/yd ³	1.45 2,445	1.68 2,833	1.90 3,204	1.60 2,698	1.80 3,035	1.95 3,288	1.70 2,867	1.95 3,288	2.15 3,626	2.30 3,879
Cutting width	mm ft in	3,100 10'2"	2,900 9'6"	2,800 9'2"	2,900 9'6"	2,800 9'2"	2,650 8'8"	2,800 9'2"	2,750 9'	2,700 8'10"	2,500 8'2"
Weight	kg lb	11,900 26,235	10,900 24,030	10,700 23,589	11,900 26,235	11,560 25,485	11,700 25,794	13,200 29,101	12,050 26,566	11,900 26,235	11,600 25,574

GP: Loading bucket with Liebherr Z110 teeth

HD: Heavy-duty bucket with Liebherr Z120 teeth

XHD: Heavy-duty rock bucket with Liebherr Z120 teeth

Face shovel attachment

with shovel boom 6.00 m / 19'7"

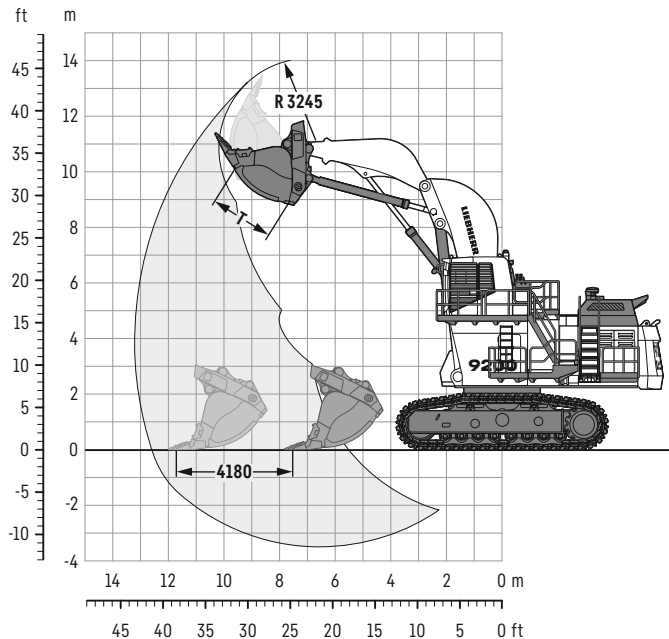

Digging envelope

Stick length	m	4.37
	ft in	14'4"
Max. reach at ground level	m	12.60
	ft in	41'4"
Max. dumping height	m	9.00
	ft in	29'5"
Max. crowd length	m	4.20
	ft in	13'8"
Bucket opening width T	m	2.20
	ft in	7'1"

Forces

Max. crowd force at ground level (ISO 6015)	kN	868
	lbf	195,134
Max. crowd force (ISO 6015)	kN	924
	lbf	207,723
Max. breakout force (ISO 6015)	kN	750
	lbf	168,606

Operating weight and ground pressure

The operating weight includes the basic machine with shovel attachment and bucket 12.50 m³ / 16.35 yd³.

Pad width	mm	800
	ft in	2'6"
Weight	t	210
	sh tn	231
Ground pressure*	kg/cm ²	2.02
	psi	28.73

* according to ISO 16754

Face shovel buckets

For materials class according to VOB, Section C, DIN 18300	< 5	< 5	5 - 6	5 - 6	5 - 6	7 - 8	7 - 8	7 - 8
Typical operation according to VOB, Section C, DIN 18300	GP	GP	HD	HD	HD	XHD	XHD	XHD
Capacity ISO 7451	m ³	14.00	13.50	13.50	12.50	11.50	12.50	11.50
	yd ³	18.3	17.7	17.7	16.4	15.0	16.4	15.0
Suitable for material up to a specific weight of	t/m ³	1.6	1.7	1.6	1.8	2.0	1.7	1.9
	lb/yd ³	2,698	2,867	2,698	3,035	3,373	2,867	3,204
Cutting width	mm	3,050	3,050	3,050	3,050	3,050	3,050	3,050
	ft in	10'	10'	10'	10'	10'	10'	10'
Weight	kg	17,600	17,000	18,400	17,500	17,000	18,750	18,150
	lb	38,801	37,479	40,565	38,581	37,479	41,337	40,014

GP: Loading bucket with Liebherr Z110 teeth

HD: Heavy-duty bucket with Liebherr Z120 teeth

XHD: Heavy-duty rock bucket with Liebherr Z120 teeth

Optional equipment

Undercarriage

Undercarriage bottom cover
Rock protection for travel drive

Uppercarriage

Fast fueling system with Multiflo Hydrau-Flo®
Wiggins / Banlaw counter plugs for fuel / lube trucks
Rock protection for swing gear
Steel grease lines on swing ring
Semi-automatic swing brake with joystick control
Swing ring scrapers
External grease refill station (hydraulic-powered)
Hydraulic connection with quick coupler for external grease refill station

Hydraulic system

Bio-degradable hydraulic oil
Oil cooler inlet screens

Assistance systems

Truck Loading Assistant
Operational Analytics

Automation

Bucket Filling Assistant

Cab

Front protective grid
Double A/C system
External louvers on back and side cab windows
Operator comfort package
Sliding hatch window on door

Attachment

Piston rod guard for bucket cylinder (BH)
Piston rod guard for hoist cylinder (BH/FS)

Specific solutions

Arctic package (-20 °C / -4 °F, -35 °C / -31 °F, -50 °C / -58 °F)
Sound attenuation package
High altitude package

Safety

Automatic fire suppression system
Isolation & energy dissipation system - MDG 41 compliant

General

Maritime transport packaging

Electric drive

Automatic cable reeler



Mining excavator



Mining truck



Mining dozer



Mining dragline



Service tools



Customer service

Quality commitment

- Liebherr-Mining Equipment Colmar, France, ISO 9001 certified
- Compliance of materials tested in laboratory
- Quality control during all stages of production
- CE certified, MDG 15 & MDG 41 compliant

Subject to technical modifications. All comparisons and claims of performance are made with respect to the prior Liebherr model unless specifically stated.

Liebherr-Mining Equipment Colmar SAS

49 rue Frédéric Hartmann • 68025 Colmar Cedex, France • Phone +33 369 49 20 00
info.lec@liebherr.com • www.liebherr.com • www.facebook.com/LiebherrMining